

Operating Instructions



A30199 / A40199 Tie-Dex II Tool

NOTES:

1. Use only BAND-IT Tie-Dex bands with A40199 tool and Tie-Dex Micro bands with A30199 tool.
2. To Free handles: Squeeze handle together and move holding clips to center.
3. To Install clamps: Follow instructions on page 2.
4. When tensioning band: Always let pull-up handle return to its original position. If pull-up handle is stuck in between strokes, push back down for full stroke. Correct tension is reached when tension release lever moves toward cut-off handle and locks pull-up handle against tool body.
5. Periodically check tightness of head mounting screws and re-tighten if necessary.

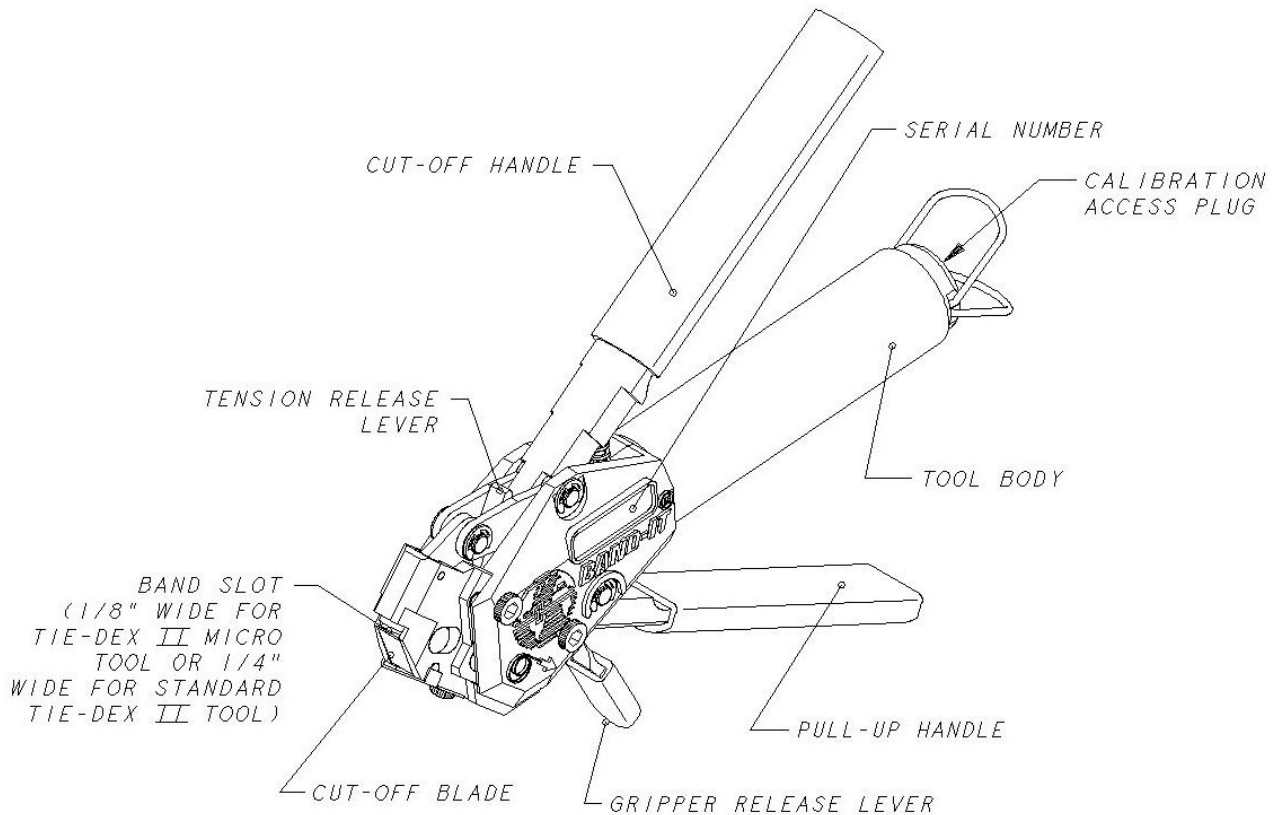

Replacement Parts

Tool Model	Serial Numbers	Cutter Blade Kit	Blade	Knife (See sheet 3)	Mounting Pin	Factory calibrated tension	Tension range
A40199 1/4"	All	A40699	A40688	New – A67787 Old – A40788	M06487	150 ±5 LBS	100-180 LBS
A30199 1/8"	Less than 21000	A46799	A46787	A48087	M06987	80 ±5 LBS	50-100 LBS
A30199 1/8"	21000 and above	A47899	A47887	A48087	M06987	80 ±5 LBS	50-100 LBS

Operating Instructions



A30199 / A40199 Tie-Dex II Tool

1. Create double wrapped clamp by feeding end of band through narrow slot on buckle twice. Pull on clamp tail by hand to reduce loop diameter for faster installation on small objects. Squeeze gripper release lever and insert band as far as possible.

CAUTION: Never use band as a single wrapped clamp!

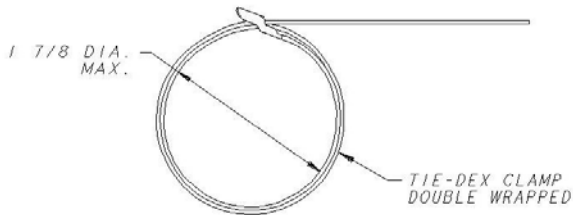

2. Repeatedly squeeze pull-up handle until handle locks against tool body. Always allow pull-up handle to return to its original position after each stroke. Correct tension is reached when pull-up handle locks against tool body.

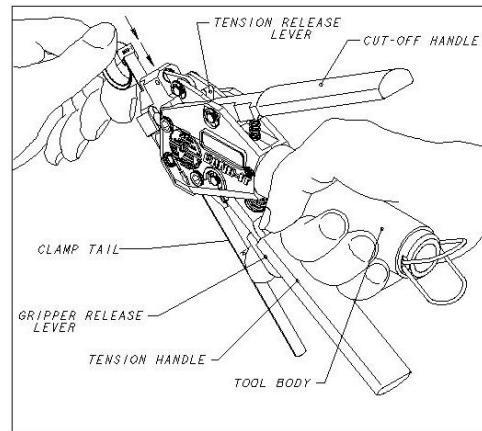
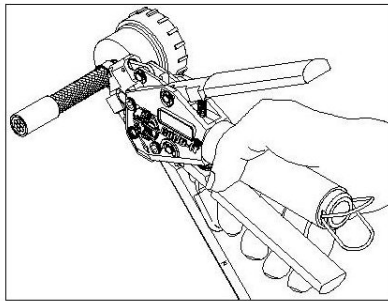

3. Squeeze cut-off handle once against tool body to form lock and trim excess band. Tension handle will release. Remove band from tool.

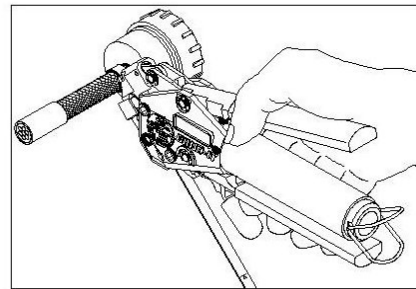

4. To loosen or remove clamp before locking and cut-off, squeeze gripper release lever on tool and pull band out.
5. To loosen or remove clamp after pull-up handle locks against tool body, squeeze pull-up handle and push tension release lever forward. Let tension handle return to its original position, then use gripper release lever and pull band out.
6. Completed clamp may be covered with shrink wrap or tape for protection.

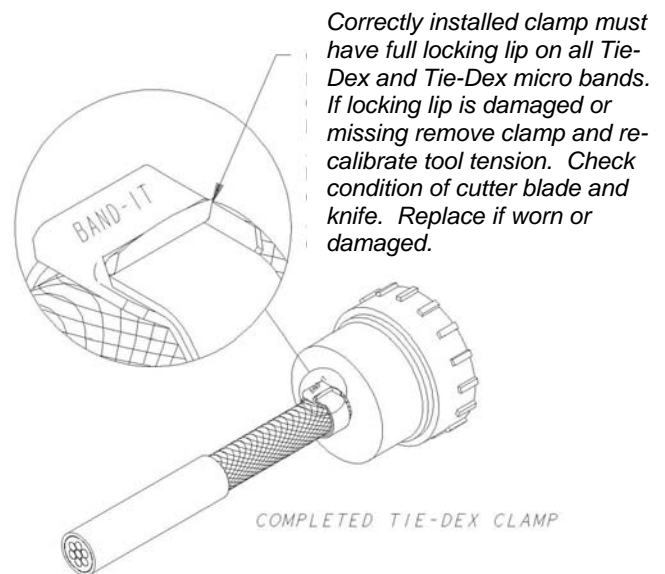

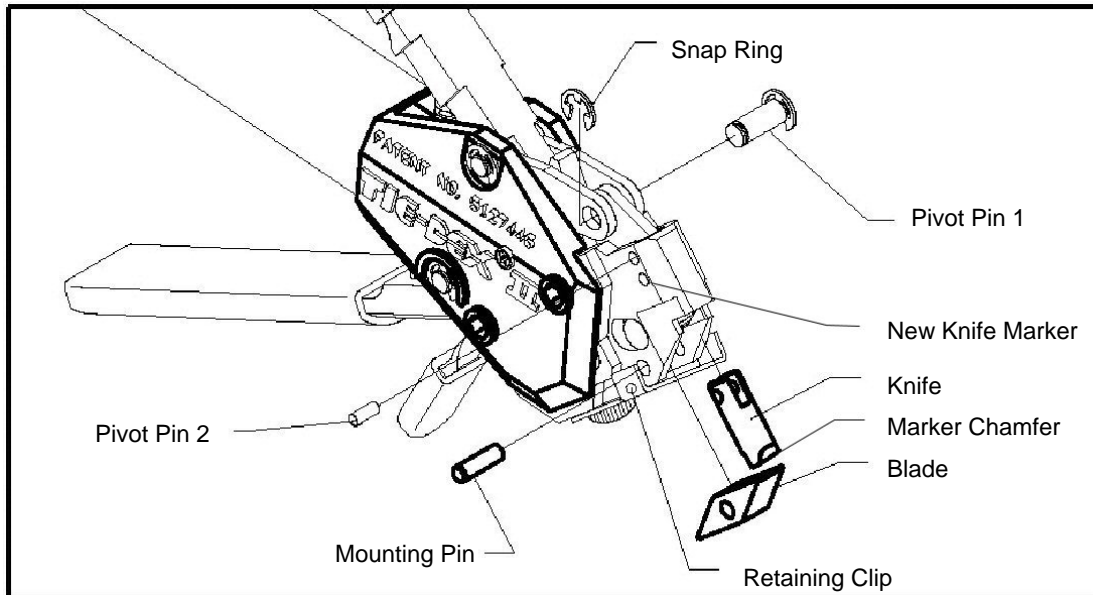

To replace Blade: Bend clip downward and remove mounting pin to free old cutter blade. Assemble new cutter blade as shown. Cutter blade is reversible, with two cutting edges. Cutter blade and mounting pin are provided with kit as replacement parts.

To replace Knife: Remove blade as described above. Remove snap rings and pivot pin 1. Line up pivot pin 2 with access hole on tool head and slide out sideways. Remove knife and replace with new one. Reinstall all parts in reverse order. Actuate cut-off handle to verify correct installation of components.

Please Note: On the A40199: If the tool head has a marker hole as shown, the replacement cutter knife is the new part number A67787. Note that this new knife has an identifying chamfer on the front edge as shown.

Refer to website for warranty information: <http://www.band-it-idex.com/warranty.html>