

4348-BA9180EN-5999-011524

**MULTIFUNCTION
DIGITAL PANEL INSTRUMENT**



TYP 9180
MODBUS PROTOCOL COMPATIBLE

INSTRUCTIONS MANUAL

Valid for instruments from Firmware BM2.00



EU-Konformitätserklärung (nach EN ISO/IEC 17050-1:2010)

EU-Declaration of conformity (in accordance with EN ISO/IEC 17050-1:2010)

Name des Ausstellers: burster präzisionsmesstechnik gmbh & co kg
Issuer's name:

Anschrift des Ausstellers: Talstr. 1-5
Issuer's address: 76593 Gernsbach, Germany

Gegenstand der Erklärung: Digitalanzeiger / DIGILOW
Object of the declaration: Digital Display / DIGILOW

Modellnummer(n) (Typ): 9180 / 9186
Model number / type:

Diese Erklärung beinhaltet obengenannte Produkte mit allen Optionen
This declaration covers all options of the above product(s)

Das oben beschriebene Produkt ist konform mit den Anforderungen der folgenden Dokumente:

The object of the declaration described above is in conformity with the requirements of the following documents:

Dokument-Nr. <i>Documents No.</i>	Titel <i>Title</i>	Ausgabe <i>Edition</i>
2011/65/EU	Richtlinie zur Beschränkung der Verwendung bestimmter gefährlicher Stoffe in Elektro- und Elektronikgeräten <i>Directive on the restriction of the use of certain hazardous substances in electrical and electronic equipment</i>	2011
2014/35/EU	Richtlinie zur Harmonisierung der Rechtsvorschriften der Mitgliedsstaaten über die Bereitstellung elektrischer Betriebsmittel zur Verwendung innerhalb bestimmter Spannungsgrenzen auf dem Markt <i>Directive on the harmonization of the laws of the Member States relating to the making available on the market of electrical equipment designed for use within certain voltage limits</i>	2014
2014/30/EU	Richtlinie zur Harmonisierung der Rechtsvorschriften der Mitgliedsstaaten über die Elektromagnetische Verträglichkeit <i>Directive on the harmonization of the laws of the Member States relating to electromagnetic compatibility</i>	2014
EN 61010-1	Sicherheitsbestimmungen für elektrische Mess-, Steuer-, Regel- und Laborgeräte – Teil 1: Allgemeine Anforderungen <i>Safety requirements for electrical equipment for measurement, control and laboratory use – Part 1: General requirements</i>	2010 + Cor.:2011
EN 61326-1	Elektrische Mess-, Steuer-, Regel- und Laborgeräte – EMV-Anforderungen – Teil 1: Allgemeine Anforderungen <i>Electrical equipment for measurement, control and laboratory use – EMC requirements – Part 1: General requirements</i>	2022
EN 55011	Industrielle, wissenschaftliche und medizinische Geräte – Funkstörungen – Grenzwerte und Messverfahren <i>Industrial, scientific and medical equipment – Radio-frequency disturbance characteristics – Limits and methods of measurement</i>	2022

Gernsbach 12.01.2023 ppa. Christian Karius
Ort / place Datum / date Quality Manager

Dieses Dokument ist entsprechend EN ISO/IEC 17050-1:2010 Abs. 6.1g ohne Unterschrift gültig
According EN ISO/IEC 17050 this document is valid without a signature.

burster präzisionsmesstechnik gmbh & co kg

Talstr. 1-5 · DE-76593 Gernsbach
Tel. (+49) 07224-6450
info@burster.com

Geschäftsführer/Managing Director: Matthias Burster
Handelsregister/Trade Register: Gernsbach
Registergericht/Register Court: Mannheim HRA 530170

Kompl./Gen. Partn.: burster präzisionsmesstechnik Verwaltungs-GmbH
Handelsregister/Trade Register: Gernsbach
Registergericht/Register Court: Mannheim HRB 530130

INTRODUCTION TO THE SERIES TYP 9180

This catalogue does not constitute a formal agreement.

All information given in this manual is subject to change without notice.

The SERIES TYP9180 brings a new philosophy in digital panel instrumentation which is expressed by multipurpose, modular-concept devices providing a rich array of basic functions and advanced capabilities.

With a fully MODULAR DESIGN, it is possible to implement a wide variety of applications by only adding the adequate options.

Intelligence within allows the meter to recognize the options installed and ask for the necessary parameters to properly function within desired margins. The basic instrument without output options omits these data in the program routines.

The instrument's CALIBRATION is made at the factory eliminating the need for adjustment potentiometers.

Any circuit or option that may need any adjust incorporates a memory where calibration parameters are stored, making it possible the optional cards be totally interchangeable without need of any subsequent adjust.

Custom CONFIGURATION for specific applications can be made quickly and easily through five front panel keys, following structured choice menus aided by display prompts at each programming step.

Other features of the TYP9180 family include:

- CONNECTIONS via plug-in terminal blocks without screws and CLEMP-WAGO clips cable retention system.
- DIMENSIONS
96x48x120 mm DIN 43700
- CASE MATERIAL UL-94 V0-rated polycarbonate.
- PANEL INSTALLATION by means of single part fingertip without screws.

To guarantee the meter's technical specifications, it is advised to check its calibration at periodical intervals according to the ISO9001 standards for the particular application operating criteria. Calibration should be performed at the factory or in a qualified laboratory.

DIGITAL PANEL INSTRUMENT

MODEL TYP9180

Index

1 - TYP9180 model overview	6 - 7
1.1 Mode RUN: front-panel description	8
1.2 Mode PROG: front-panel description	9
2 - Getting started	10
2.1 Power and connectors.....	11 - 12
2.2 Programming instructions.....	13 - 14
2.3 Programming guide	15
3 - Programming module 10. Input configuration diagram.....	16 - 17
3.1 Program process input. Menu 11	18 - 20
3.1.1 Connections (V, mA).....	21 - 22
3.2 Program load cell input. Menu 12	23 - 24
3.2.1 Connections (mV/ V)	25
3.3 Program Pt100 input. Menu 13	26 - 27
3.3.1 Connections	28
3.4 Program thermocouple input. Menu 14	29 - 31
3.4.1 Connections (J, K, T, R, S, E).....	32
3.5 Program potentiometer input. Menu 15.....	33
3.5.1 Connections	33

DIGITAL PANEL INSTRUMENT

MODEL TYP9180

4 - Programming module 20. Display configuration diagram	34 - 35
4.1 Scaling. Menus 21 and 22.....	36 - 45
4.2 Integrator. Menu 23.....	46 - 48
4.3 Display options, Filters and Round	49
4.3.1 Display options. Menu 24	50- 51
4.3.2 Filters. Menu 25.....	52 - 53
4.3.3 Round. Menu 26	54
4.4 Automatic volume calculation. Menu 27	55 - 58
5 - Front-panel functions and remote inputs	
5.1 Front-panel functions	59 and 65
5.2 Remote inputs	66
5.2.1 Table of remote input logic functions	67 - 69
5.2.2 Program remote input logic functions.....	70
6 - Programming parameters lockout.....	71
6.1 Lockout routine.....	72
7 - Output options.....	73 - 74
8 - Technical specifications	75 - 76
8.1 Dimensions and mounting	77
9 - Warranty	78
10 - Declaration of conformity	80
ANNEXES. Index.....	82

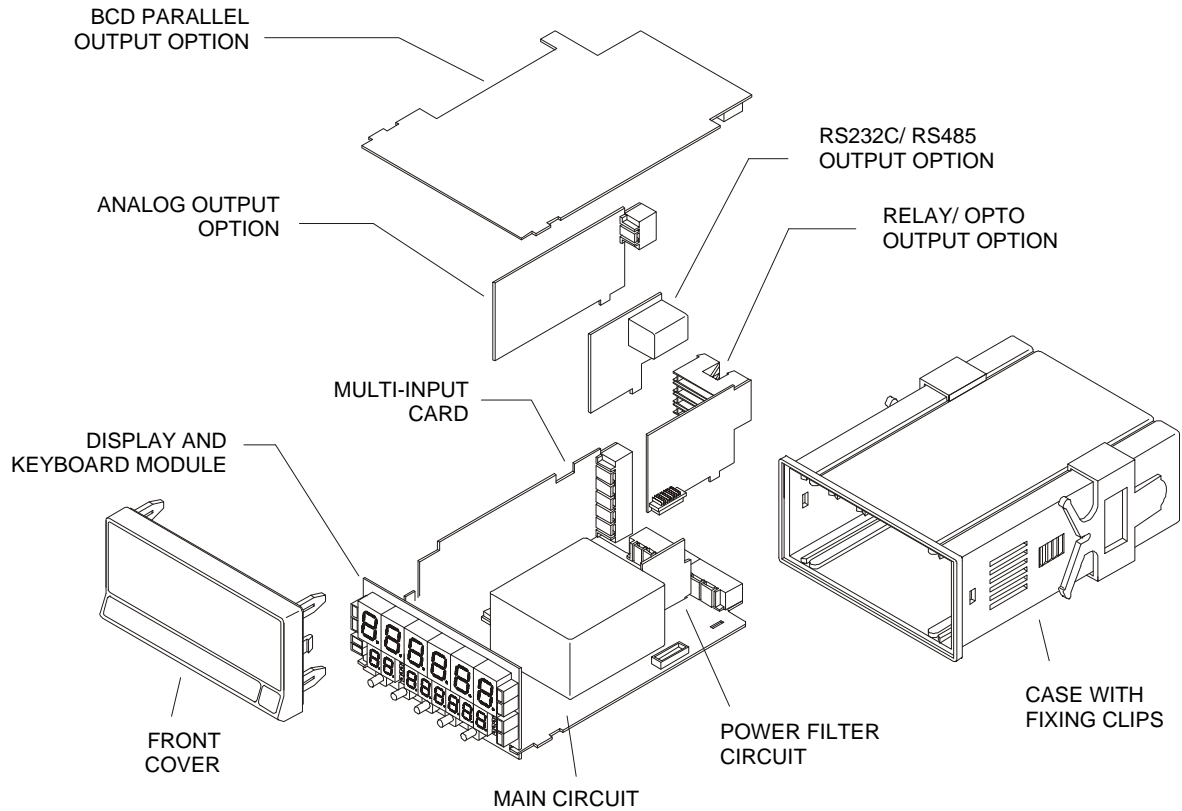

1. MODEL TYP9180

The TYP9180 model incorporates new technical and functional characteristics including more filtering options, software lockout, a variety of programmable remote inputs and many other performance capabilities that provide an extraordinary flexibility to adapt to a wide range of indication and control needs.

The TYP9180 model is a digital multifunction instrument whose input stage admits, as selected by the user the following configurable input types:

- PROCESS (V, mA)
- LOAD CELL (mV/V)
- Pt100 SENSOR
- THERMOCOUPLE (J, K, T, R, S, E)
- POTENTIOMETER

The input card allows direct connection to a wide variety of transducers, transmitters or primary sensors without need for changing any component or circuit. The meter's configuration for a particular input type is made entirely by software.

An optional 8-digit totalizer/integrator accumulates time dependent quantities using a timebase or either stores batch readings.

Standard features of the basic instrument include the reading of the input variable plus a selectable second variable in the lower display, max and min readings detection, remote hold, tare operation and a full complement of programmable logic functions.

Special software capabilities are program lock-out for individual menus or the entire program parameters, as well as the possibility to restore factory configuration at any time.

In addition, a variety of plug-in output cards can be installed at any time to meet further system requirements: analog or digital control via 0-10V/ 4-20mA or relay/ transistor outputs and communication via serial RS232C/ RS485 or BCD parallel. Each option has a separate programming module to configure relating parameters, which is activated when the card is installed.

All output options are optoisolated from input signal and power supply.

The basic instrument is a soldered assembly composed of the main board, the display and keyboard module, the power filtering circuit and the multi-input card (see page 6).



This instrument conforms to the following directives: EMC 2004/108/CEE and LVD 2006/95/CEE
Caution: Read complete instructions to ensure safety protections.

1.1 - RUN MODE: FRONT-PANEL FUNCTIONS

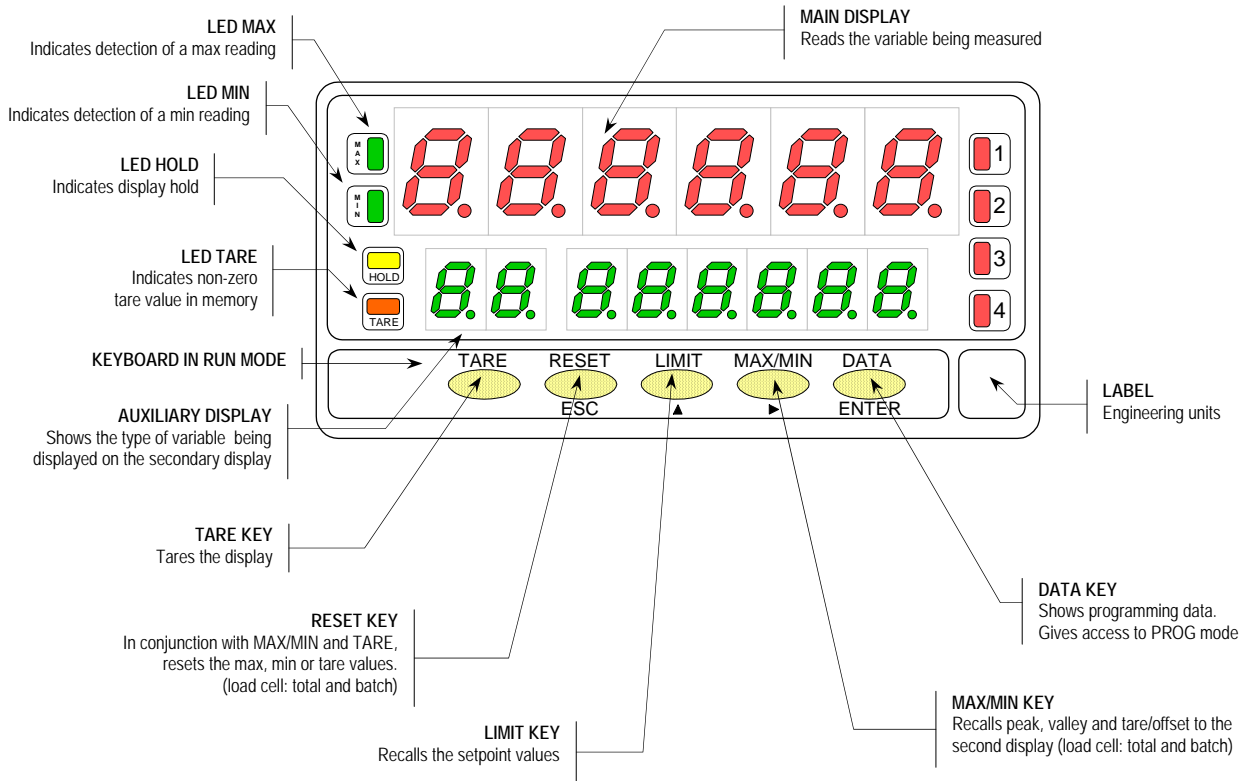

1.2 - PROG MODE: FRONT-PANEL FUNCTIONS

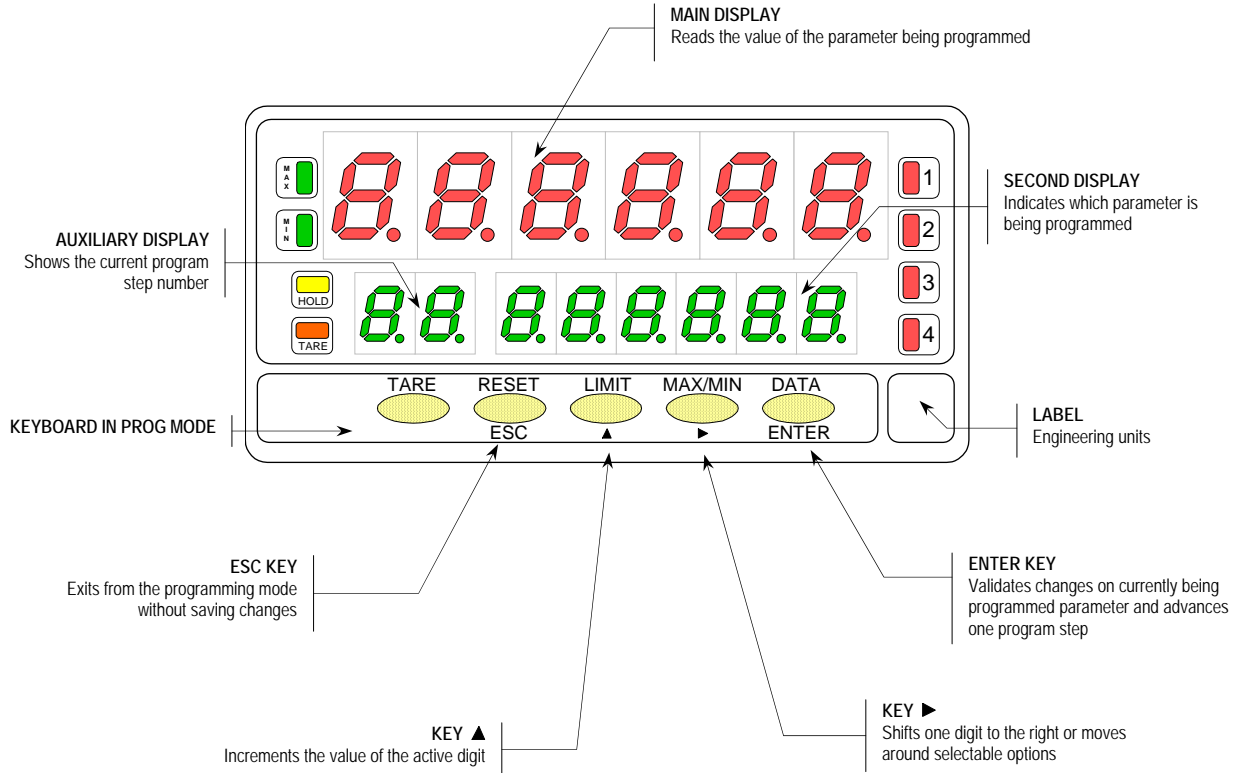

2. GETTING STARTED

Packing contents

- ❑ Instructions manual in English, including Declaration of Conformity.
- ❑ Digital panel meter model TYP9180.
- ❑ Accessories for panel mounting (sealing gasket and fixing clips).
- ❑ Accessories for wiring connections (plug-in terminal block connectors with a fingertip key).
- ❑ Wiring label stucked to the plastic case
- ❑ Set of labels with engineering units
- ✓ *Check the packing is complete.*

Configuration

Power supply (pages 11 & 12)

- ❑ The instruments with 115/230V AC power supply are set by default for a supply voltage of 230V (USA market 115 V AC).
- ❑ The instruments with 24/48V AC power supply are set by default for a supply voltage of 24V.
- ✓ *Check wiring label before applying power to the instrument.*

Programming instructions (pages 13, 14 & 15)

- ❑ The software is divided into several independently accessible modules for configuration of the input, the display, the setpoint outputs, the analog output, the communication output and the logic inputs.
- ✓ *Read carefully this section.*

Input types (pages 16 & 17)

- ✓ *Verify input configuration before connecting the input signal.*

Programming parameters lockout (page 54)

- ❑ The instrument is shipped from the factory with all programming levels accessible to the operator. Software allows selective lockouts of the programming parameters.
- ✓ Lockout is recommended after programming the instrument.

2.1 - Power supply and connector

To access hardware configuration, remove the meter from the case as shown in figure 11.1.

115/230 V AC: The instruments with 115/230 V AC power are shipped from the factory for 230V AC (USA market 115V AC), see figure 11.2. To change supply voltage to 115V AC, set jumpers as indicated in table 11.1. The wiring label should be modified to match new setup.

24/48 V AC: The instruments with 24/48V AC power supply are shipped from the factory for 24V AC, see figure 11.2. To change supply voltage to 48V AC, set jumpers as indicated in table 11.1. The wiring label should be modified to match new setup.

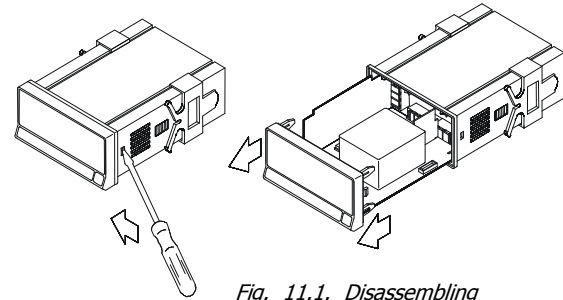

Fig. 11.1. Disassembling

Table 1. Jumper settings.

Pin	1	2	3	4	5
230V AC	-	[Jumper]		[Jumper]	
115V AC	[Jumper]		[Jumper]		-
48V AC	-	[Jumper]		[Jumper]	
24V AC	[Jumper]		[Jumper]		-

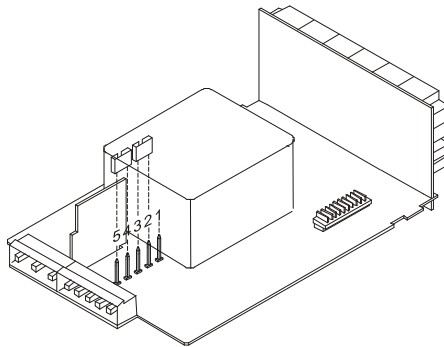

Fig. 11.2. Jumper location for 230 V or 48 V AC

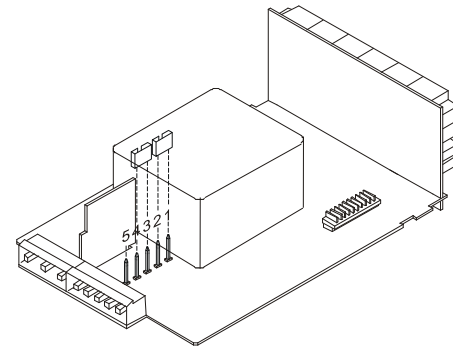
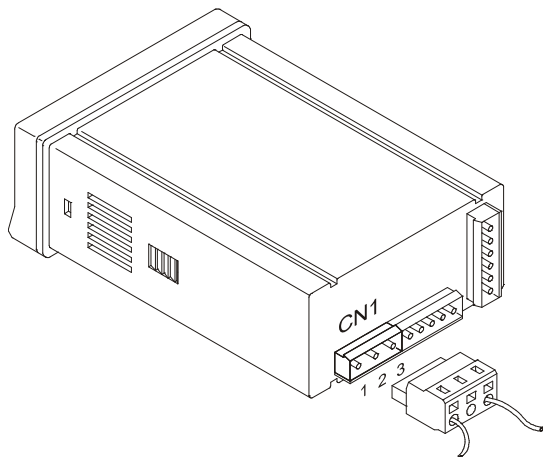

Fig. 11.3. Jumper location for 115 V or 24 V AC

POWER CONNECTION - CN1



PIN 1 - AC PHASE
PIN 2 - GND (GROUND)
PIN 3 - AC NEUTRAL



INSTALLATION

To meet the requirements of the directive EN61010-1, where the unit is permanently connected to the mains supply it is obligatory to install a circuit breaking device easy reachable to the operator and clearly marked as the disconnect device.

WARNING

In order to guarantee electromagnetic compatibility, the following guidelines for cable wiring must be followed:

- Power supply wires must be routed separated from signal wires. *Never* run power and signal wires in the same conduit.
- Use shielded cable for signal wiring and connect the shield to ground of the indicator (pin2 CN1).
- The cable section must be $\geq 0.25 \text{ mm}^2$

If not installed and used according to these instructions, protection against hazards may be impaired.

CONNECTORS

To perform wiring connections, remove the terminal block from the meter's connector, strip the wire leaving from 7 to 10 mm exposed and insert it into the proper terminal while pushing the fingertip down to open the clip inside the connector as indicated in the figure.

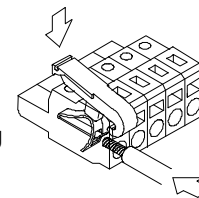

Proceed in the same manner with all pins and plug the terminal block into the corresponding meter's connector.

Each terminal accepts cables of section between 0.08 mm^2 and 2.5 mm^2 (AWG 26 ÷ 14).

The blocks provide removable adaptors into each terminal to allow proper fastening for cable sections of $< 0.5 \text{ mm}^2$.

2.2 - Programming Instructions

Access to the programming mode

When power is applied to the instrument, the display briefly illuminates all segments and LED's then shows the software version and finally enters in the normal mode. Press **ENTER** to enter in the programming mode. The second display shows the indication "-Pro-" (fig. 13.1).

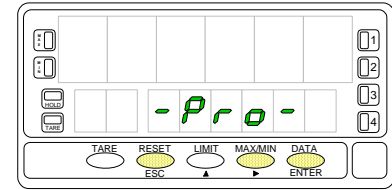

Fig. 13.1. PROG mode first step (-Pro- stage)

Exit from the programming mode without saving data

From any step of the program routines, a push of **ESC** returns the meter to the -Pro- stage. From this point, a new push of **ESC** shows momentarily the indication "qUIt" on the second display, the meter exits from the programming mode, restores the previous configuration and returns to the normal operation. Any parameter change made before exiting in this mode is discarded.

Save changes in the configuration

In the programming mode, the instrument returns to the -Pro- stage at the end of each program menu. The data changes are not saved at this point, to keep changes in the configuration parameters press **ENTER**, the second display shows momentarily the indication "StorE" while the new configuration is saved in the memory. After, the instrument returns to the run mode.

Guidelines on programming instructions

The programming software is divided into 6 modules. Each module is organized in several independently accessible menus and each menu contains a list of parameters necessary to configure a specific function of the meter.

From the -Pro- stage, press repeatedly **▶** to cycle around the existing modules: module 10 = Input configuration, module 20 = display configuration, module 30 (if option is installed) = setpoints, module 40 (if option is installed) = analog output, module 50 (if option is installed) = serial outputs and module 60 = logic functions. Press **ENTER** to get access to the selected module.

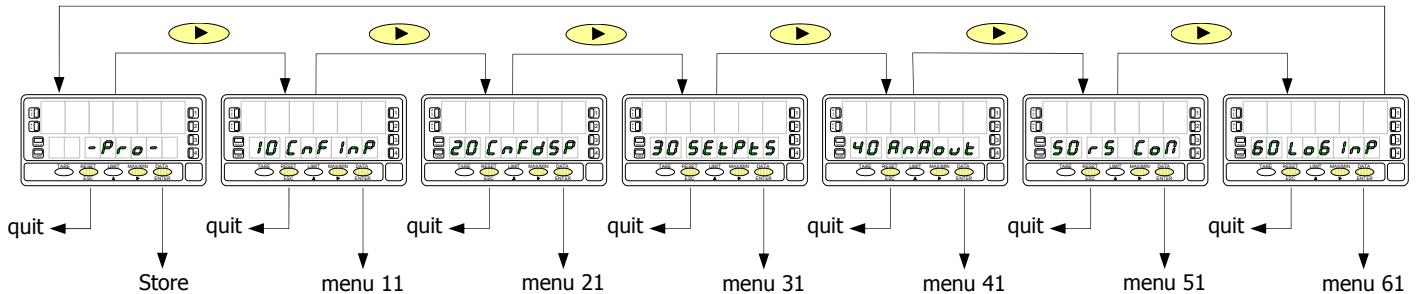

The programming instructions are composed by a general description and a series of step-by-step instructions to be followed sequentially. Each menu step is represented by an illustration of the display and keyboard module with indications (displays and LED's), reference [page number. figure number] and a text describing the action of each key at current step.

[page n°/figure n°] Mnemo

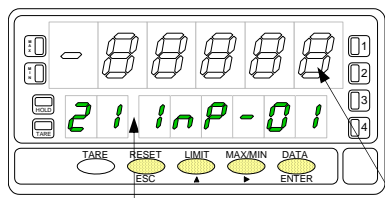

In the step-by-step instructions, you are given the action of the three buttons mainly used to program data. The normal procedure at each step is to push on a number of times to make changes and push on to validate changes and advance to the next programming step. At the end of a complete menu sequence the meter returns to the -Pro- stage, where:

- to save changes and exit
- to discard changes and exit
- to select among available options

The auxiliary display shows the identification of the current menu.

The second display shows the parameter being programmed.

With respect to the figures in the step-by-step instructions, the display indications may have the following meanings:

1. / The first display shows one of the available options with filled-out segments. That means that the display shows the choice made previously. The use of allows to select from available options.
2. / A series of black "8" also represents the display indication of a previous choice, with the difference that it cannot be changed in the current step. If it is already the desired parameter, you may exit from the menu by a push of without making changes or, if wanted to modify it, a push of advances the meter to the next step where changes are allowed.
3. / A series of white "8" represents any numerical value that is programmed by the and buttons.

2.3 - Programming guide

The steps listed here below should be followed to properly configure the indicator according to desired input. Steps are marked depending on whether they are mandatory (**M**), recommended (**R**) or optional (**op**).

Process indicator:

1. Input programming, pages. 16 - 20 (**M**).
2. Signal wiring, pages. 21 - 22 (**M**).
3. Scaling, pages. 34 - 45 (**M**).
4. Configure the integrator option, pages 46 - 48 (**op**)
5. Program remote inputs, pages. 66 - 69 (**R**).
6. Install and configure output options, refer to respective manual (**op**).
7. Lockout programming, pages. 71 - 72 (**R**).

Load cell indicator:

1. Input programming, pages. 16, 23 and 24 (**M**).
2. Signal wiring, page. 25 (**M**).
3. Configure the display, pages. 50 - 54 (**M**).
4. Program remote inputs, pages. 66 - 69 (**R**).
5. Install and configure output options, refer to respective manual (**op**).
6. Lockout programming, pages. 71 - 72 (**R**).

Pt100 thermometer:

1. Input programming, pages. 17, 26 and 27 (**M**).
2. Signal wiring, page. 28 (**M**).
3. Program display options, pp. 34 - 35 and 42 - 45 (**R**).
4. Program remote inputs, pages. 66 - 69 (**R**).
5. Install and configure output options, refer to respective manual (**op**).
6. Lockout programming, pages. 71 - 72 (**R**).

Thermocouple meter:

1. Input programming, pages. 17 and 29 - 31 (**M**).
2. Signal wiring, page. 32 (**M**).
3. Program display options, pp. 34 - 35 and 42 - 45 (**R**).
4. Program remote inputs, pages. 66 - 69 (**R**).
5. Install and configure output options, refer to respective manual (**op**).
6. Lockout programming, pages. 71 - 72 (**R**).

Potentiometer indicator:

1. Input programming, pages. 17 and 33 (**M**).
2. Set excitation jumper, page. 18 (**M**).
3. Signal wiring, page. 33 (**M**).
4. Scaling, pages. 34 - 45 (**M**).
5. Configure the integrator option, pages 46 - 48 (**op**)
6. Program remote inputs, pages. 66 - 69 (**R**).
7. Install and configure output options, refer to respective manual (**op**).
8. Lockout programming, pages. 71 - 72 (**R**).

3. INPUT CONFIGURATION

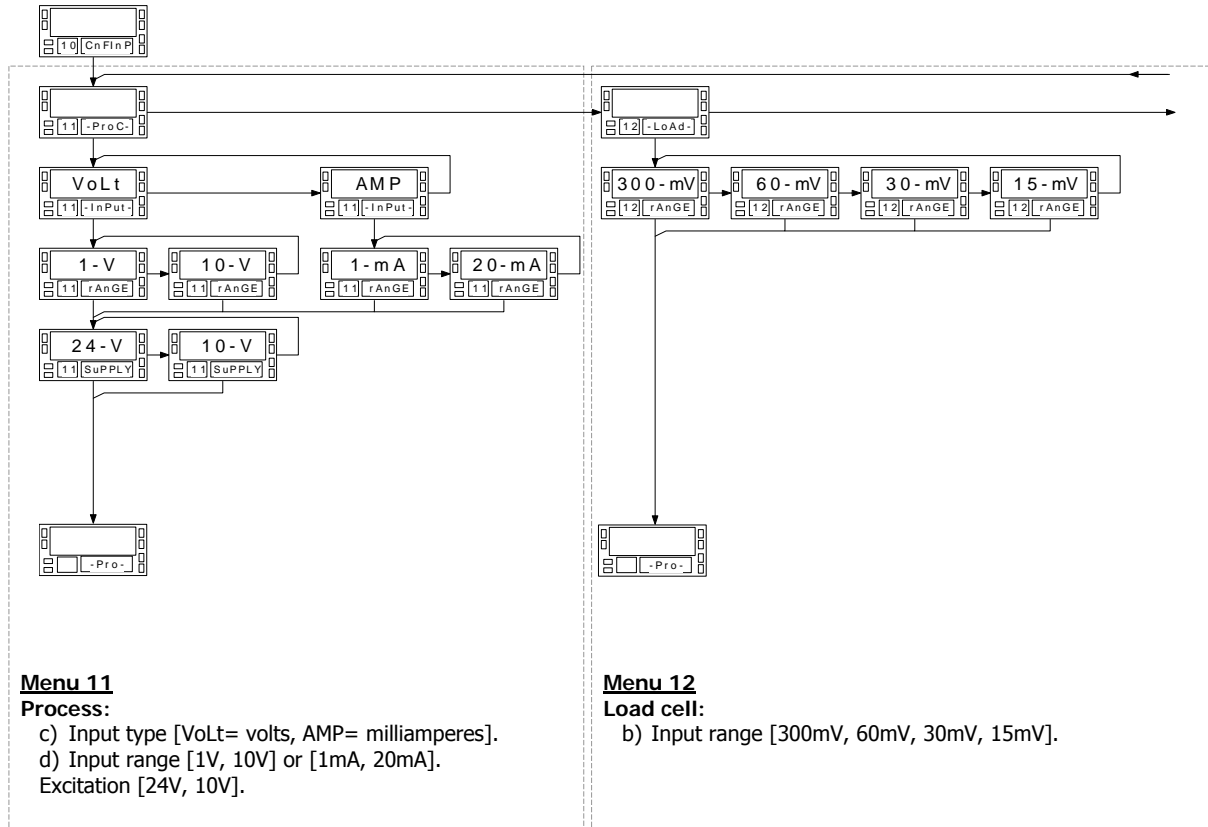

MODULE 10 - INPUT CONFIGURATION ("CnFinP")

The figure shows the complete input configuration module which is divided into five menus. Each menu corresponds to a specific configuration of the meter. You may only need to program the parameters of the desired configuration (process, load cell, thermocouple, Pt100 or potentiometer).

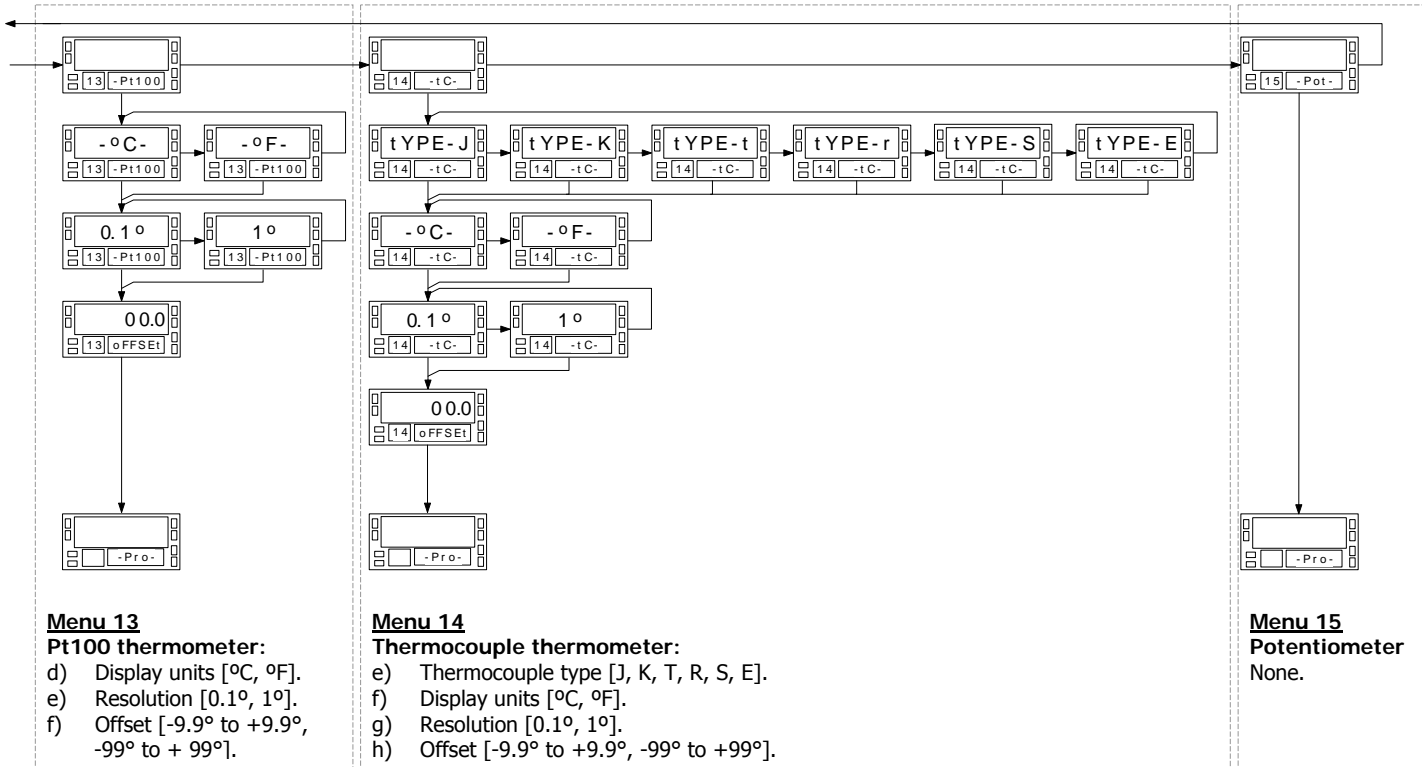

To have access to the input configuration module, press **ENTER** to pass from the run mode to the programming mode and press **▶** to make the lower displays show the indication "10 CnFInP" (fig. 18.1).

3.1 - Program process input

The process indicator accepts inputs in volts or milliamperes and provides three selectable transducer excitation voltages.

Configurable parameters:

- a) Type of input : volts or milliamperes
- b) Input range in volts or milliamperes :
 - "1V", range -1V to +1V,
 - "10V", range -10V to +10V,
 - "1mA", range -1mA to +1mA,
 - "20mA", range -20mA to +20mA,
- c) Sensor excitation. Available excitation voltages are 24V, 10V or 5V. The 5V supply is set by selecting 10V in the software routines then placing a jumper in the position shown in figure 18.2.

Fig. 18.1: Input configuration module

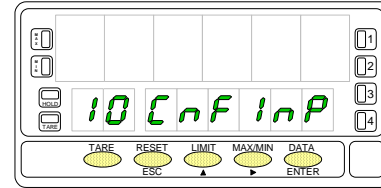
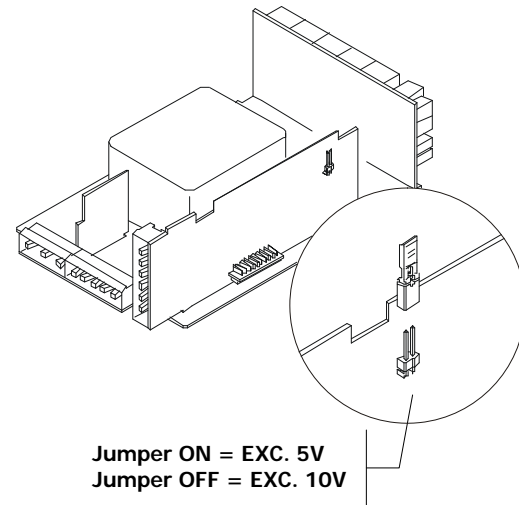

Fig. 18.2: 10V/5V excitation jumper



Menu 11 - PROCESS

This menu configures the meter as a process indicator. Programmable parameters are the input type (volts or milliamperes), input range and transducer's excitation.

[19.1] Access to menu 11

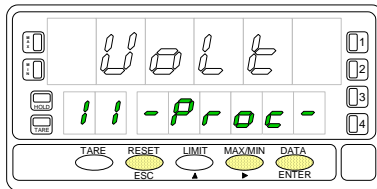
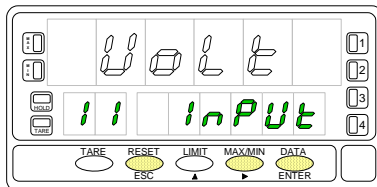

Figure 19.1 shows the indication corresponding to the access stage to process input configuration. The following actions are available at this stage:

- Access to the process input parameters.
- Skip this menu and pass to the load cell configuration (p. 24).
- Exit from this routine and return to the -Pro- stage.

[19.2] Input type



Menu 11 Input. Select input type.

The display shows the previous configuration [**VoLt** = voltage input, **AMP** = current input]. Press to change this parameter if desired.

- Validate the choice and advance to the next programming step.
- Exit from this routine and return to the -Pro- stage.

[19.3] Input range

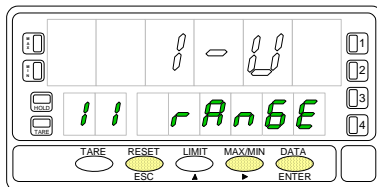

Menu 11 rAnGE. Select input range.

There are two ranges for each input type [**1-V / 10-V** if input type is 'VoLt' and **1mA / 20mA** if input type is 'AMP']. Press to change this parameter if desired.

- Validate changes and advance to the next programming step.
- Exit from this routine and return to the -Pro- stage.

[20.1] Excitation Supply

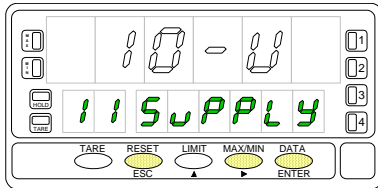

Menu 11 SuPLY. Select excitation voltage.

The meter provides two software selectable excitation voltages [10-V and 24-V] that alternate on the display by pressing the  key. To set the excitation supply to 5V DC, select the option '10-V' and place the jumper shown in figure 18.2.

 ENTER

Validate changes, exit from this menu and return to the -Pro- stage.

 ESC

Exit from this routine and return to the -Pro- stage.

3.1.1 - Signal wiring (V, mA)

Refer to wiring instructions in page 12.

Instrument's rear view

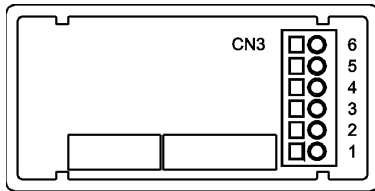

- PIN 6 = -EXC [excitation supply (-)]
- PIN 5 = +EXC [excitation supply (+)]
- PIN 4 = +IN [input mA (+)]
- PIN 3 = -IN [input V (-) or mA (-)]
- PIN 2 = +IN [input V (+)]
- PIN 1 = N/C [not connected]

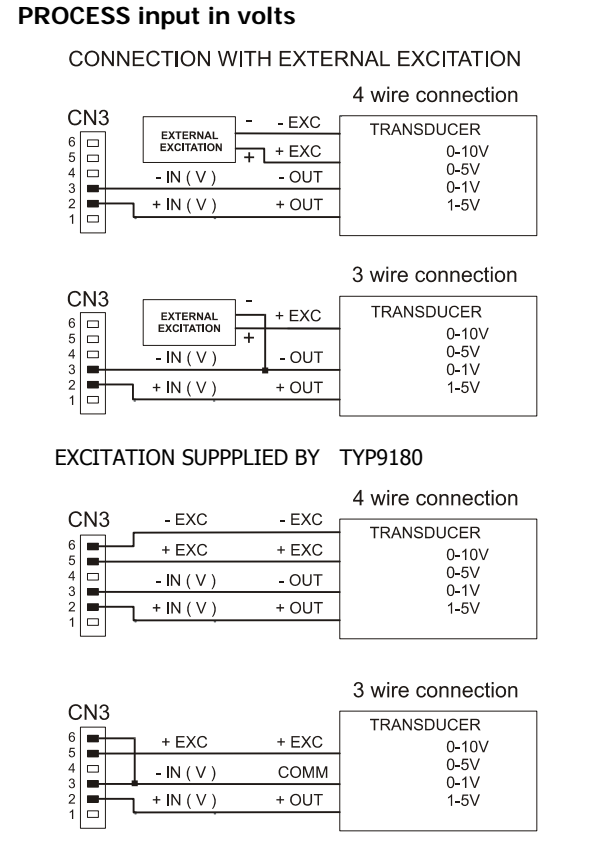

PROCESS indicator with mA input

CONNECTION WITH EXTERNAL EXCITATION

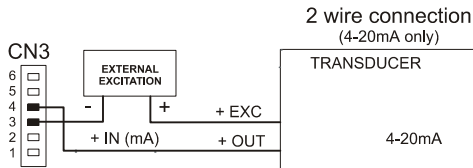
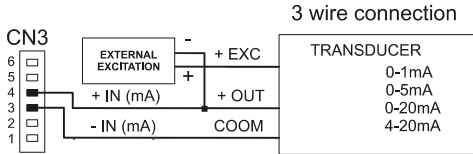
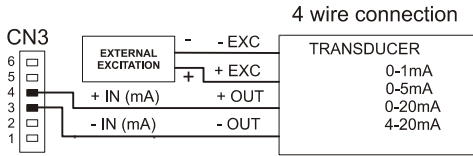

EXCITATION SUPPLIED BY TYP9180

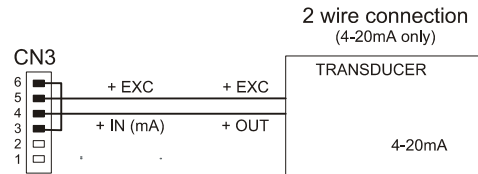
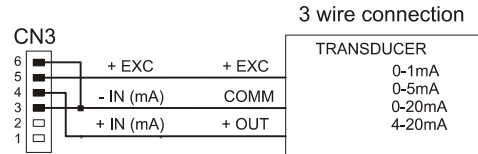
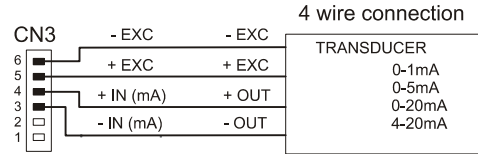

3.2 - Program load cell input

Refer to the cell manufacturer's documentation, particularly with respect to the cell sensitivity and supply voltage specifications.

As load cell indicator the meter's function is to measure forces (weight, pressure, torque...) which are converted to a millivolts signal by a bridge type transducer such as load cell and applied to the input of the meter.

The instrument supplies 10V or 5V to feed the transducer as selected by jumper (fig. 25.1). These voltages can feed up to 4 cells connected in parallel with 10V or up to 8 cells connected in parallel with 5V without need for an external source (fig. 25.2).

Example:

4 cells with 2mV/V sensitivity are parallel connected to the meter input. With an excitation voltage of 10V, the max. voltage generated by the cells is 20mV. In the same case but with an excitation of 5V, the max. voltage generated by the cells is 10mV.

Software configuration requires selection of the input range which may be selected high enough for the maximum input signal to avoid overloads.

There are four ranges: $\pm 15\text{mV}$, $\pm 30\text{mV}$, $\pm 60\text{mV}$ and $\pm 300\text{mV}$

Example:

If a weighing process gives 20mV to the meter input with maximum load, the best range should be 30mV.

BATCH FUNCTION

Operation by logic input

Function n° 30 -**BATCH**- is designed to be used in batch weighing applications where it is required to read the accumulated total of a product quantity per cycle, or day and to keep count of the number of weighing operations.

A sensor connected to a logic input with function 30 detects the presence of a weight and pulls low the logic input which makes the instrument add the measured value to the totalizer and increment the batch counter in one unit.

The meter keeps in memory the totalizer and the batch count in a power failure or disconnection from the power source. These parameters can be displayed permanently on the second display as selected by the user.

Menu 12 - LOAD CELL

This menu configures the meter as a load cell indicator and allows selecting the input range. Available excitation voltages for this configuration are 10 and 5V DC which are selected by a plug-in jumper (see fig. 25.1).

[24.1] Access to menu 12

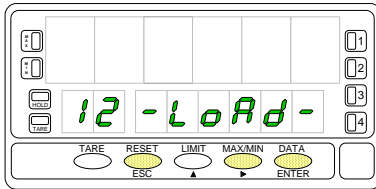



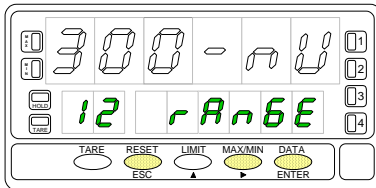



Figure 24.1 shows the indication corresponding to the input level to load cell input configuration. The following actions are available at this stage:



-  Access to the load cell input parameters.
-  Skip this menu and pass to the Pt100 configuration (p. 26).
-  Exit from this routine and return to the -Pro- stage.

[24.2] Input range



Menu 12 rAnGE. Select input range.

Press repeatedly the  key to cycle around available options [300mV, 60mV, 30mV and 15mV].

-  Validate changes, exit from this menu and return to the -Pro- stage.
-  Exit from this routine and return to the -Pro- stage.

3.2.1 - Load cell wiring connections (mV/ V)

Refer to wiring instructions page 12.

Instrument's rear view

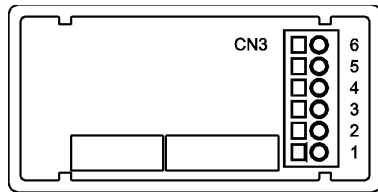

- PIN 6 = -EXC [excitation supply (-)]
- PIN 5 = +EXC [excitation supply (+)]
- PIN 4 = Not connected
- PIN 3 = -mV [input signal mV (-)]
- PIN 2 = Not connected
- PIN 1 = +mV [input signal mV (+)]

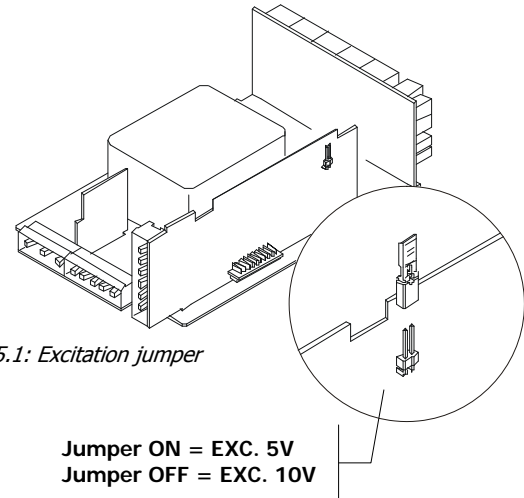
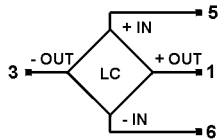
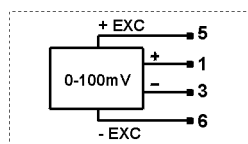

Fig. 25.1: Excitation jumper

Fig. 25.2: Wiring schematics



Load cell



0-100mV Transducer

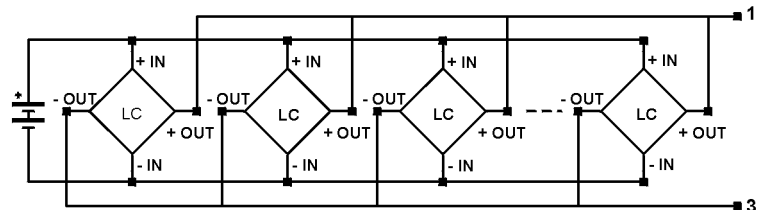

More than 4 cells connected in parallel

3.3 - Program Pt100 input

Please refer to your sensor documentation.

When configuring the meter for Pt100 input, the temperature ranges are set automatically depending on temperature units and resolution:

Input	Range (0.1 °)	Range (1°)
Pt100	-100.0 to +800.0 °C	-100 to +800 °C
	-148.0 to +1472.0 °F	-148 to +1472 °F

The Pt100 software menu allows selection of temperature units (Celsius or Fahrenheit), resolution (degrees or tenths of degree) and a display offset. The offset may be used to compensate for a difference that may exist between the temperature under measurement and the temperature read by the sensor.

The offset is programmable from -9.9 to +9.9 with 0.1° resolution and from -99 to +99 with 1° resolution.

Example:

The instrument is used to control the temperature of a baking oven, but the sensor is located at a distance from the oven where the temperature is 2 degrees below. To correct from this deviation, the offset should be programmed to +2 counts (with 1° resolution).

Configurable parameters for this input are:

- Reading units in Celsius "°C" or Fahrenheit "°F".
- Resolution to units "1°" or tenths "0.1°".
- Offset. Programmable $\pm 99^\circ$ counts.

After entering these parameters, the display range and linearization are adjusted automatically.

Menu 13 - THERMOMETER FOR Pt100 SENSOR

For this configuration, the meter requires the following information: readout units, resolution and optionally, an offset value.

[26.1] Access to menu 13

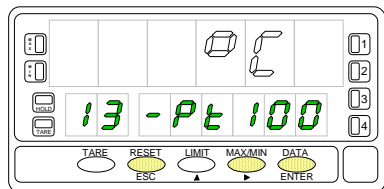



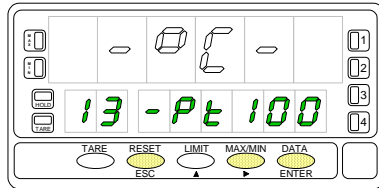



Figure 26.1 shows the indication corresponding to the access level to Pt100 input configuration. The following actions are available at this stage:



-  Access to the Pt100 input parameters.
-  Skip this menu and pass to the Pot input menu (p. 33).
-  Exit from this routine and return to the -Pro- stage.

[27.1] Units



Menu 13 -Pt100. Select temperature units.

Use  to select desired units ["°C" = Celsius, "°F" = Fahrenheit].

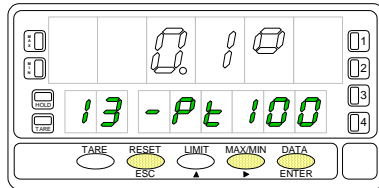

-  Validate changes and pass to the next program step.
-  Exit from this routine and return to the "-Pro-" stage.

[27.2] Resolution



Menu 13 -Pt100. Select resolution.



Press  to switch between the indications "0.1°" (resolution to tenths of degree) and "1°" (resolution to degrees).

-  Validate changes and pass to the next program step.
-  Exit from this routine and return to the "-Pro-" stage.

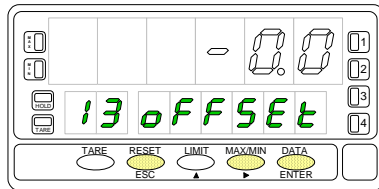

[27.3] Offset



Menu 13 oFFSEt. Program the display offset.

The previously programmed offset appears on the display with the first digit in flash. To change the value, press  to increment the active digit value (the first digit can only be '0' or a minus sign). Press  to shift to the next digit to be modified and repeat these operations until desired offset is completed on the display (max values are ±99° with 1° resolution and ±9.9° with 0.1° resolution).

The TARE LED lights whenever the offset has been set to a value other than zero.

-  Validate changes and return to the -Pro- stage.
-  Exit from this routine and return to the "-Pro-" stage.

3.3.1 - Pt100 sensor connection

Refer to wiring instructions in page 12.

Instrument's rear view

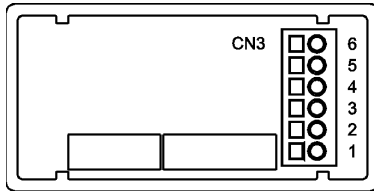

- PIN 6 = Not connected
- PIN 5 = Pt100 COMM
- PIN 4 = Not connected
- PIN 3 = Pt100
- PIN 2 = Not connected
- PIN 1 = Pt100

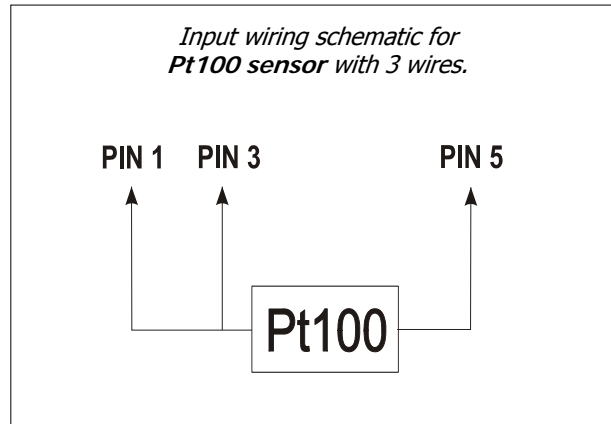

3.4 - Program thermocouple input

Please refer to your thermocouple documentation.

When configuring the meter for thermocouple input, the temperature ranges are set automatically according to sensor type, temperature units and resolution:

Input	Range (0,1 °)	Range (1°)
TC J	-200,0 to +1100,0 °C	-200 to +1100 °C
	-328,0 to +2012,0 °F	-328 to +2012 °F
TC K	-200,0 to +1200,0 °C	-200 to +1200 °C
	-328,0 to +2192,0 °F	-328 to +2192 °F
TC T	-150,0 to +400,0 °C	-150 to +400 °C
	-238,0 to +752,0 °F	-238 to +752 °F
TC R	-50,0 to +1750,0 °C	-50 to +1750 °C
	-58,0 to +3182,0 °F	-58 to +3182 °F
TC S	-50,0 to +1750,0 °C	-50 to +1750 °C
	-58,0 to +3182,0 °F	-58 to +3182 °F
TC E	-200,0 to +1000,0 °C	-200 to +1000 °C
	-328,0 to +1832,0 °F	-328 to +1832 °F

The thermocouple software menu allows selection among several types of thermocouple, temperature units (Celsius or Fahrenheit), resolution (degrees or tenths of degree) and a display offset. The offset may be used to compensate for a difference that may exist between the temperature under measurement and the temperature read by the sensor. The offset is programmable from -9.9 to +9.9 with 0.1° resolution and from -99 to +99 with 1° resolution.

Example:

The instrument is used to control the temperature of a baking oven, but the sensor is located at a distance from the oven where the temperature is 2 degrees below. To correct from this deviation, the offset should be programmed to -2 counts (with resolution of 1°).

Configurable parameters for this input are:

- Thermocouple type [J, K, T, R, S, E].
- Reading units in Celsius "°C" or Fahrenheit "°F".
- Resolution to units "1°" or tenths "0.1°".
- Offset. Programmable $\pm 99^\circ$ counts.

After entering these parameters, the display range and linearization for the selected thermocouple input are adjusted automatically.

Menu 14 - THERMOCOUPLE METER

The thermocouple meter configuration provides a choice of six TC types: J, K, T, R, S and E. Other selectable parameters include temperature units, resolution and offset.

[30.1] Access to menu 14

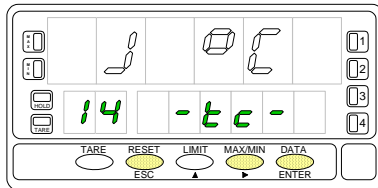
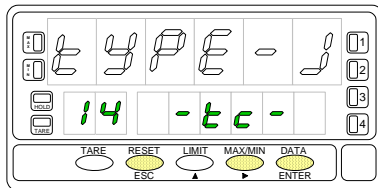

Figure 30.1 shows the indication corresponding to the thermocouple input selection. Press one of the following keys:

- Access to the thermocouple input configuration menu.
- Pass to the menu 15 - Potentiometer (p.33).
- Exit from this menu and go to the "-Pro-" stage.

[30.2] Thermocouple type



Menu 14 -tc-. Select thermocouple type.

Press to shift around available inputs ['tYPE-J', 'tYPE-K', 'tYPE-t', 'tYPE-r', 'tYPE-S' or 'tYPE-E'].

- Validate changes and advance to the next program step.
- Exit this routine and return to the "-Pro-" stage.

[30.3] Units

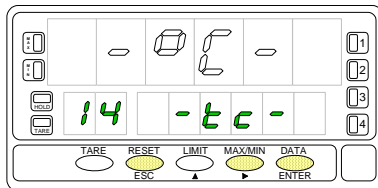

Menu 14 -tc-. Select temperature units.

Use to select desired units ["°C" = Celsius, "°F" = Fahrenheit].

- Validate changes and pass to the next program step.
- Exit from this routine and return to the "-Pro-" stage.

[31.1] Resolution

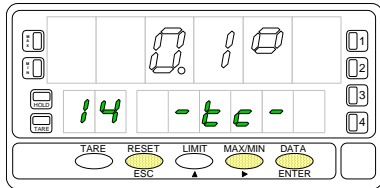

Menu 14 -tc-. Select resolution.

Press to switch between the indications "0.1°" (resolution to tenths of degree) and "1°" (resolution to degrees).

Validate changes and advance to the next program step.

Exit from this routine and return to the "-Pro-" stage.

[31.2] Offset

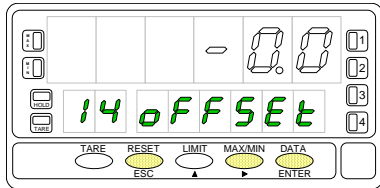

Menu 14 oFFSEt. Program the display offset.

The previously programmed offset appears on the display with the first digit in flash.

To change the value, press to increment the active digit value (the first digit can only be '0' or a minus sign). Press to shift to the next digit to be modified and repeat these operations until desired offset is completed on the display (max values are $\pm 99^\circ$ with 1° resolution and $\pm 9.9^\circ$ with 0.1° resolutions).

The TARE LED lights whenever the offset has been set to a value other than zero.

Validate changes and return to the "-Pro-" stage.

Exit from this routine and return to the "-Pro-" stage.

3.4.1 - Thermocouple wiring connections

Refer to the wiring instructions given in page 12.

Instrument's rear view

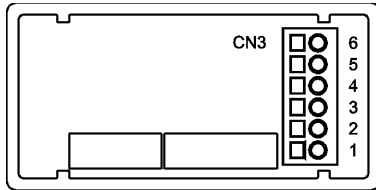

- PIN 6 = Not connected
- PIN 5 = Not connected
- PIN 4 = Not connected
- PIN 3 = - TC
- PIN 2 = Not connected
- PIN 1 = + TC

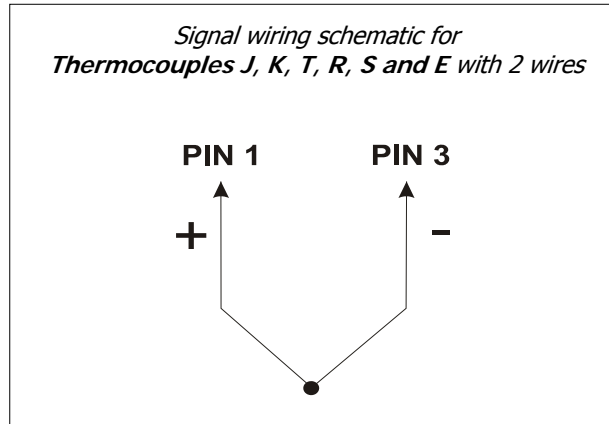

3.5 - Program potentiometer input

Please refer to the potentiometer manufacturer's documentation.

When setting the indicator for potentiometer input, no input configuration parameter is required by software. The excitation supply voltage is selected by a jumper (see fig.18.2). This output voltage is applied between the potentiometer HI and LO ends while the cursor position determines the signal level applied to the meter input.

Menu 15 - POTENTIOMETER

[33.1] Access to the menu 15

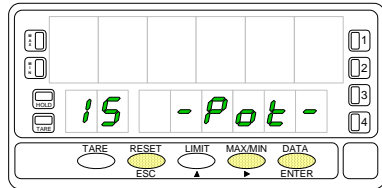





Figure 33.1 shows the indication corresponding to the potentiometer input selection. Press one of the following keys:

-  Validate the POT configuration and go to the -Pro- stage.
-  Pass to the menu 11 - Process (p. 19).
-  Exit from this menu and go to the "-Pro-" stage.

3.5.1 - POT input connection

Refer to the wiring instructions given in page 12.

Instrument's rear view

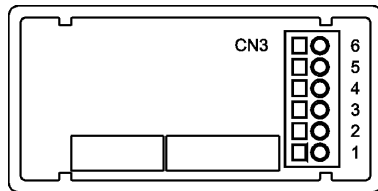

- PIN 6 = - EXC
- PIN 5 = POT HI
- PIN 4 = Not connected
- PIN 3 = POT LO (COMM)
- PIN 2 = POT CENTRAL
- PIN 1 = Not connected

Signal wiring schematic for *potentiometer with 3 wires*

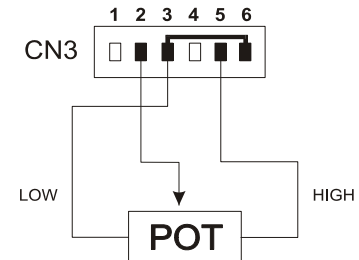

4. DISPLAY CONFIGURATION

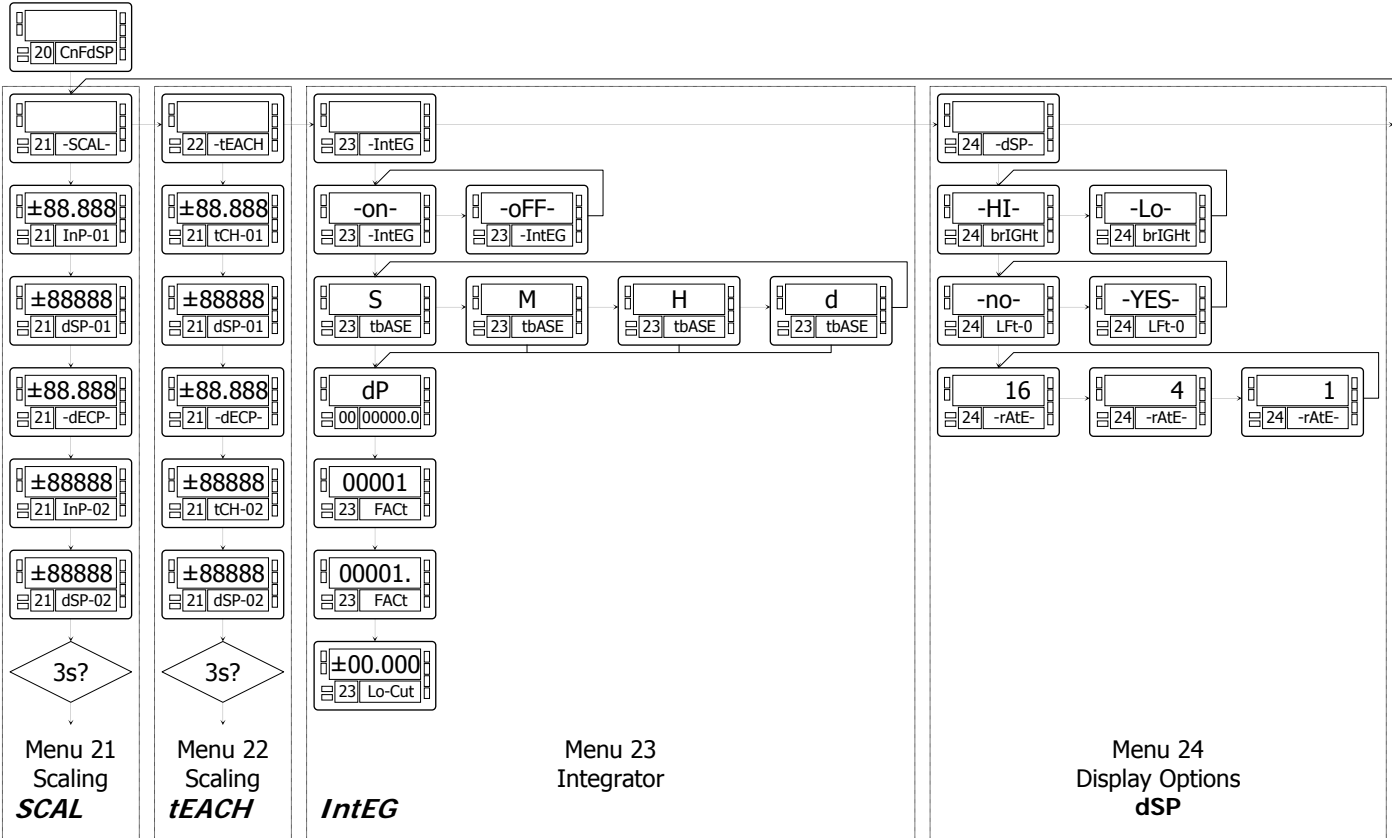

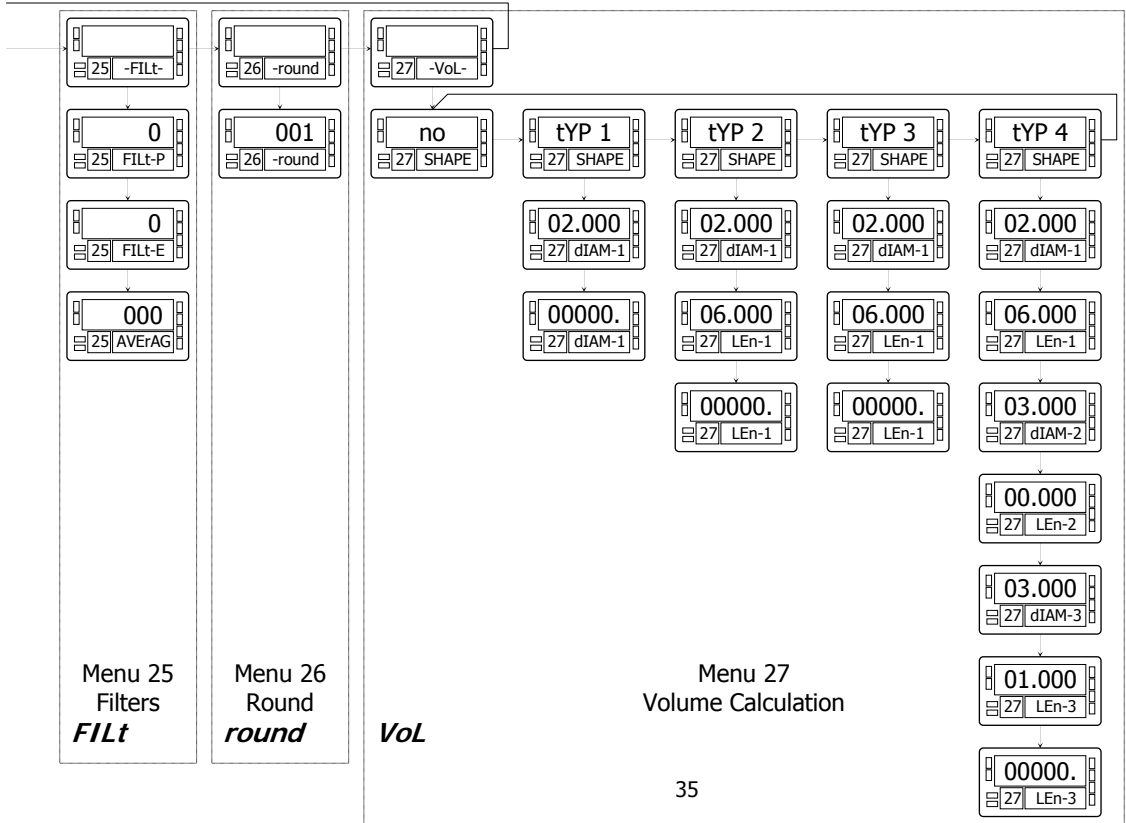

4.1. Scaling

When the instrument is configured as a process, load cell or potentiometer indicator, the display must be scaled to fit a particular application.

Scaling the display consists of assigning a display value to every input value.

For linear processes this is accomplished by programming two points $-(input1, display1)$ and $(input2, display2)$ -. The line plotted between these points establishes a linear relationship in which any input value produces a unique display value. Reverse operation is accomplished by reversing the display values or the input values (see figure).

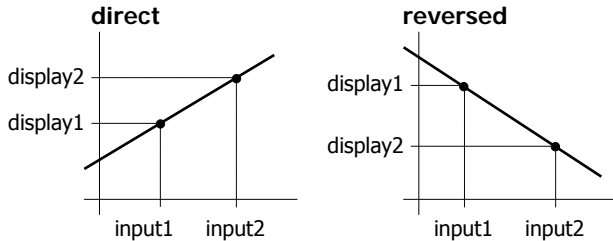

The two points should be located near the process limits for the best possible accuracy.

For non-linear processes it is possible to set up to 30 pairs input-display. Each two consecutive points are linked by a straight segment forming all together a curve that represents a non-linear relationship between input and display.

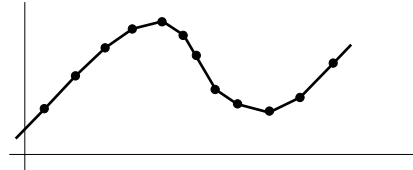

The greater the number of points used, the more accurate the measurement will be.

The input values must be programmed in always increasing or always decreasing order. Two different display values should not be assigned to the same input value.

The display values can be programmed in any order. The same display value can be assigned to different input values.

For input values below the first programmed point, the display follows the slope calculated between points 1 and 2 of the scale. For input values over the last programmed point, the display follows the slope calculated between the last two points of the scale.

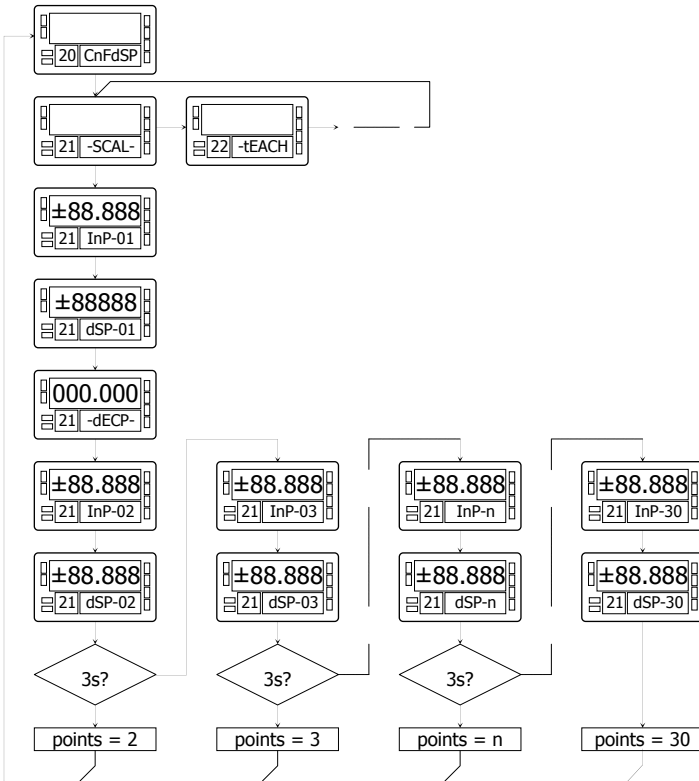

The meter offers two methods to scale the display; **SCAL** (menu 21) and **tEACH** (menu 22). The diagram represents the program routine for the SCAL menu, but both routines are the same except that in the tEACH menu, the input values are denoted by tCH in the second display.

SCAL method

The input and display values are programmed manually by the front-panel keys. This method can be used when the transducer gives accurate calibrated known signals for each point of the process.

tEACH method

The input values are taken from the actual input signal present at the input connector at each point and the corresponding display values are programmed manually. This method is suitable when the transducer is connected to the process and the process can be brought to the desired conditions while programming.

Linearization points

The first two scaling points are accessible by entering in the proper scaling menu with the ENTER key. The accesses to program scaling points above 2 is achieved by a press of 3 seconds after programming the parameter 'dSP-02' in the SCAL or tEACH menus. The subsequent input-display pairs follow one another by successive pressings of ENTER. When sufficient numbers of points have been programmed, the user can exit from the routine and save the programmed data by a press of 3 seconds from the display value of the last point. In normal operation, the non-programmed pairs are missed out from the display calculation.

Menu 21 - SCAL (process, load cell and potentiometer)

This menu allows entering the input values and corresponding display values necessary to scale the meter. The decimal point location helps to read the indication in the desired units.

[38.1] Access to menu 21

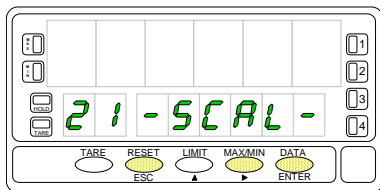



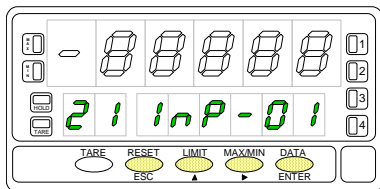



Figure 38.1 shows the indication corresponding to the access level to the SCAL menu. Press one of the following keys:



-  **ENTER** Access to the programming of the first menu parameter.
-  Skip this menu and pass to menu 22 - Teach (page 42).
-  **ESC** Exit this menu and return to the -Pro- stage.

[38.2] Input 1



Menu 21 InP-01. Program input value for point 1.



The previously programmed value appears on the display with the first digit blinking. Press repeatedly the  key to increment the active digit until it takes desired value (first digit can only be '0' or a minus sign). Press  to move to the next digit to be modified and repeat these operations until desired value is completed on the display.

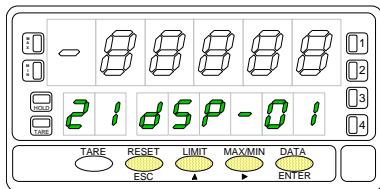

-  **ENTER** Validate changes and go to the next step.
-  **ESC** Cancel this routine and return to the -Pro- stage.

[38.3] Display 1



Menu 21 dSP-01. Program display value for point 1.

Use the procedure described on previous step ( changes value,  changes digit) to program the display value for point 1.

-  **ENTER** Validate changes and go to the next step.
-  **ESC** Cancel this routine and return to the -Pro- stage.

[39.1] Decimal point

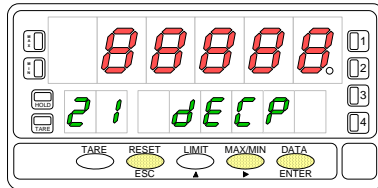

Menu 21 dECP. Decimal point position.

At this step, the decimal point goes in flash. Press the  key to rotate it to the right until it gets desired position. If no decimal point is required, it must be located to the rightmost digit as shown in figure 39.1.

 Validate selection and go to the next step.

 Cancel this routine and return to the -Pro- stage.

[39.2] Input 2

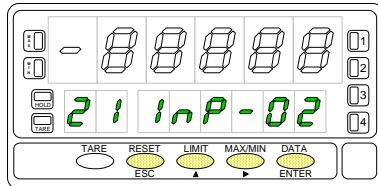

Menu 21 InP-02. Program input value for point 2.

Use the  (change value) and  (change digit) procedure to program the desired value of input 2 with sign.



 Validate the entry and proceed to the next phase.

 Cancel this routine and return to the -Pro- stage.

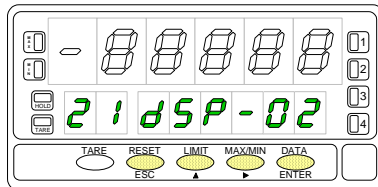
[39.3] Display 2



Menu 21 dSP-02. Program display value for point 2.

Use the  (change value) and  (change digit) procedure to program the desired value of display 2 with sign.

If you want to accept your changes and exit from the scaling routine with 2 points, press .

If you want to enter in the linearization routine press and hold  for 3 seconds.

 Cancel this routine and return to the -Pro- stage.

From the programming phase of the display 2, press and hold **ENTER** for 3 seconds to get access to the linearization routine. From the point n°3, the progress through the routine is made by pressing the **ENTER** key after programming each value. At any program step, a press of **ESC** reverts to the previous point except for the programming phase of point 3, where the **ESC** key returns the meter to the -Pro- stage. To terminate the routine for a number of points less than 30, press and hold **ENTER** for 3 seconds from the last desired point display.

[40.1] Input 3

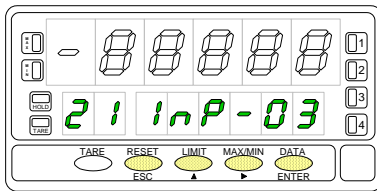

Menu 21 InP-03. Program input value for point 3.

Use the **▲** (change value) and **▶** (change digit) procedure to program the desired value of input 2 with sign.

- ENTER** Validate the entry and proceed to the next phase.
- ESC** Cancel this routine and return to the "-Pro-" stage.

[40.2] Display 3

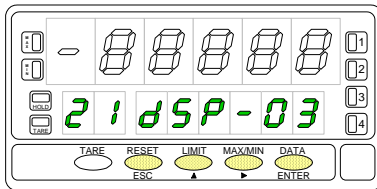

Menu 21 dSP-03. Program display value for point 3.

Press repeatedly the **▲** key to increment the active digit value and press the **▶** key to move to the next digit until the display reads the desired value with sign. The sign is programmed in the most significant digit ["0" = positive, "-" = negative].

1. If you want to validate the data and advance to the next program point, press **ENTER**.
2. If you want to validate the data and terminate the programming routine with three scaling points, press and hold **ENTER** for 3 seconds. The meter goes to the "-Pro-" stage. Press **ESC** if you want to cancel the programming and return to the "-Pro-" stage.

The same procedure is used to program the rest of the input-display points except that the **ESC** key does not return to the "-Pro-" stage, but to the previous point.

A push of **ENTER** from the programming of the display n°29 gives access to the programming of the scaling point n°30 and last of the routine. The **ESC** key reverts to the previous point.
The programming routine is terminated by a press of **ENTER** after programming the display 30.

[41.1] Value of Input 30

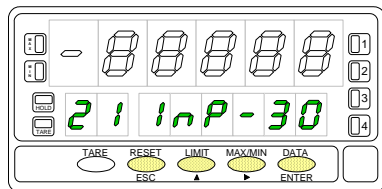

"InP-30". Programming the input of point 30.

Press repeatedly the **▲** key to increment the active digit value and press the **▶** key to move to the next digit until the display reads the desired value with sign. The sign is programmed in the most significant digit ["0" = positive, "-" = negative].

ENTER Validate the entry and advance to the next program step.

ESC Return to the programming of the previous point.

[41.2] Value of Display 30

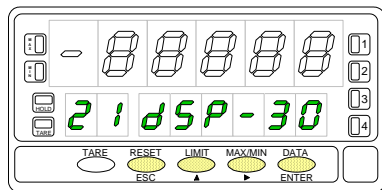

"dSP-30". Programming the display of point 30.

Use the **▲** (increment digit) and **▶** (move to next digit) procedure to set the value of the display 30 with sign. The most significant digit is used to set the sign ["0" = positive, "-" = negative].

ENTER Validate the entry, exit from this routine and go to the "-Pro-" stage.

ESC Return to the previous point.

Menu 22 - TEACH (process, load cell and potentiometer)

This menu allows scaling the display by applying input signal values and keying-in corresponding display values. The decimal point location completes the scaling sequence in the desired units.

[42.1] Access to the Menu

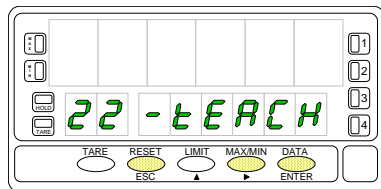
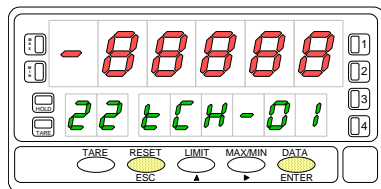

Figure 42.1 shows the indication corresponding to the access level to the tEACH menu. Press one of the following keys:

- ENTER** Access to the programming of the first menu parameter.
- ▶** Skip this menu and pass to menu 23 - Display options (page 49).
- ESC** Exit this menu and return to the -Pro- stage.

[42.2] Teach Input Signal 1



Menu 22 tCH-01. Apply input for point 1.

The main display reads the actual input signal present at the input connector. Bring the process to the conditions of the first point and press **ENTER** to take the displayed input value as the input 1 parameter and go to the programming of the corresponding display.

- ESC** Cancel this routine and return to the -Pro- stage.

[42.3] Value of Display 1

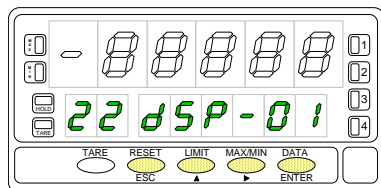

Menu 22 dSP-01. Program display value for point 1.

Use the key-in procedure to set the display corresponding to point 1 (**▲** changes the active digit value, **▶** moves to the next digit to be modified). The sign is programmed in the leftmost digit ["0" = positive, "-" = negative].

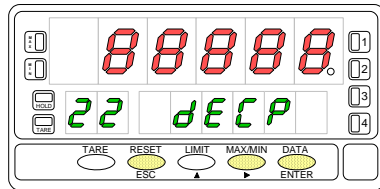

- ENTER** Validate changes and go to the next programming phase.
- ESC** Cancel this routine and return to the -Pro- stage.

[43.1] Decimal Point



Menu 22 dECP. Decimal point position.

At this step, the decimal point goes in flash. Press the  key to move it to the right until it gets desired position. If no decimal point is required, it must be located to the rightmost digit as shown in figure 43.1.

-  Validate the entry and go to the next step.
-  Cancel this routine and return to the -Pro- stage.

[43.2] Teach Input Signal 2

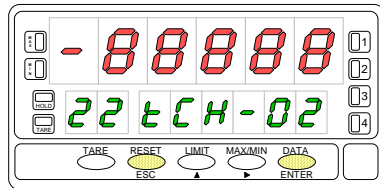

Menu 22 tCH-02. Set input value for point 2.

Bring the process to the conditions of the second scaling point. The main display reads the actual input signal present at the input connector. Press  to take the displayed input value as the input 2 parameter and go to the programming of the corresponding display.

-  Cancel this routine and return to the -Pro- stage.

[43.3] Value of Display 2

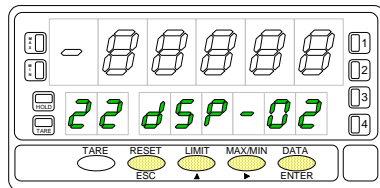

Menu 22 dSP-02. Program display value for point 2.

Use the  (change value) and  (change digit) procedure to program the desired value of display 2 with sign.

If you want to accept your changes and exit from the scaling routine with 2 points, press .

If you want to enter the linearization routine press and hold  for 3 seconds.

-  Cancel this routine and return to the -Pro- stage.

From the programming phase of the display 2, press and hold **ENTER** for 3 seconds to get access to the linearization routine. From the point n°3, the progress through the routine is made by pressing the **ENTER** key after programming each value. At any program step, a press of **ESC** reverts to the previous point except for the programming phase of point 3, where the **ESC** key returns the meter to the -Pro- stage. To terminate the routine for a number of points less than 30, press and hold **ENTER** for 3 seconds from the last desired point display.

[44.1] Teach Input Signal 3

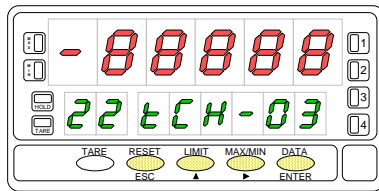

Bring the process to the conditions of the second scaling point. The main display reads the actual input signal present at the input connector. Press **ENTER** to take the displayed input value as the input 3 parameter and go to the programming of the corresponding display.

ESC Cancel this routine and return to the -Pro- stage.

[44.2] Value of Display 3

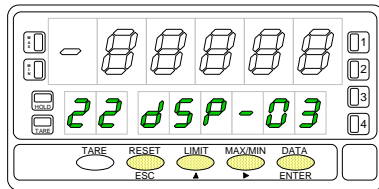

Menu 21 dSP-03. Program display value for point 3.

Press repeatedly the **▲** key to increment the active digit value and press the **▶** key to move to the next digit until the display reads the desired value with sign. The sign is programmed in the most significant digit ["0" = positive, "-" = negative].

1. If you want to validate the data and advance to the next program point, press **ENTER**.
2. If you want to validate the data and terminate the programming routine with three scaling points, press and hold **ENTER** for 3 seconds. The meter goes to the "-Pro-" stage. Press **ESC** if you want to cancel the programming and return to the "-Pro-" stage.

The same procedure is used to program the rest of the input-display points except that the **ESC** key does not return to the "-Pro-" stage, but to the previous point.

A push of **ENTER** from the programming of the display n°29 gives access to the programming of the scaling point n°30 and last of the routine. The **ESC** key reverts to the previous point.
The programming routine is terminated by a push of **ENTER** after programming the display 30.

[41.1] Teach Signal Input 30

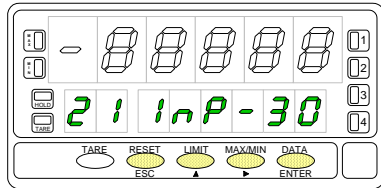

Menu 22 tCH-30. Set input value for point 30.
Bring the process to the conditions of the second scaling point. The main display reads the actual input signal present at the input connector. Press **ENTER** to take the displayed input value as the input 3 parameter and go to the programming of the corresponding display.

ESC Cancel this routine and return to the -Pro- stage.

[41.2] Value of Display 30

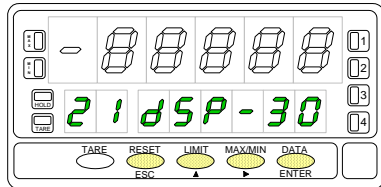

"dSP-30". Programming the display of point 30.
Use the **▲** (increment digit) and **▶** (move to next digit) procedure to set the value of the display 30 with sign. The most significant digit is used to set the sign ["0" = positive, "-" = negative].

ENTER Validate the entry, exit from this routine and go to the "-Pro-" stage.
ESC Return to the previous point.

4.2. Integrator

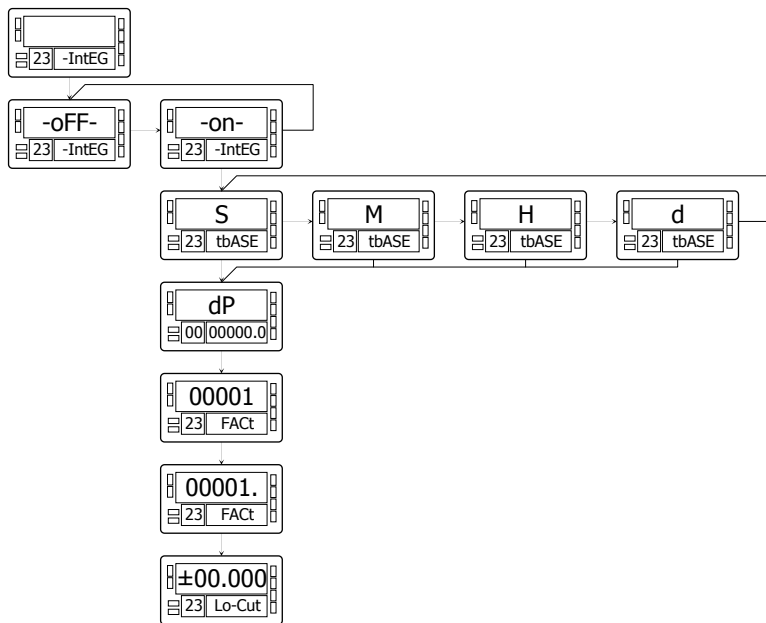

The instrument provides an 8 digit counter (or 7 digits with negative sign) that can be used to accumulate readings in totalizing+batch applications (logic function nº 30 at the rear connector) or to integrate the instantaneous reading using a timebase.

The counter is shown on the second display.

The integrator is enabled by setting the option **-on-** in the menu **23 IntEG**. When activated, the logic function nº 30 is inhibited.

(NOTE: It is not possible to activate the integrator when the automatic volume calculation option is programmed, see page 57, menu 27 -Vol-).

The value of the integrator appears on the auxiliary display permanently. This allows the instantaneous measurement and the accumulated total be read at the same time. The second display may show any other variable or be blanked if desired.

The integrator accumulates the reading of the display using a timebase in the following format:

$$\text{Total}(n) = \text{Total}(n-1) + \frac{\text{Display Reading} \times \text{Scale Factor}}{\text{Time Base}}$$

As an application example, it is required to show the total fluid quantity that pours out from a drain at a rate of 10 liters per minute. If the instantaneous value is 10.00 and is expressed in lit/min, we must select the timebase in minutes, so the totalizer may show 10.00 lit after one minute, 20.00 lit in two minutes, 600.00 lit in one hour, etc.

To read the daily consumption in m³, for instance, we should program a scale factor of 0,001 (1 lit=0,001 m³).



Menu 23 - INTEGRATOR (for process and potentiometer)

This menu allows enabling the integrator option and configuring the function parameters; time base, decimal point, scaling factor and low-cut display. This menu appears only in process and potentiometer configurations.

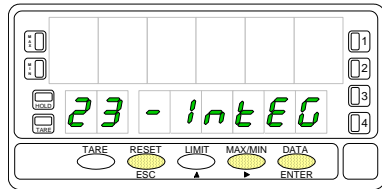
[47.1] Access to the menu



The figure 47.1 shows the indication "-IntEG" corresponding to the input stage of the integrator configuration menu.

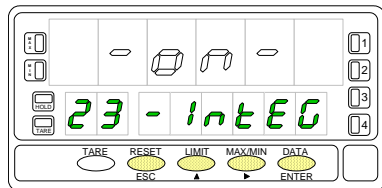

-  To access the integrator configuration.
-  To skip this menu and pass to the next menu.
-  To cancel this routine and return to the "-Pro-" stage.

[47.2] ON-OFF Selection



The first level of this menu offers two choices **-on-** and **-oFF-** to enable or disable the integrator respectively. Press the  key to switch the display between the two options to set the desired one.

If the "automatic volume calculation" option is enabled (menu 27 - VoL-) it is not possible to activate the integrator.

-  Validate the choice and go to the next program phase.
-  Cancel this routine and return to the "-Pro-" stage.

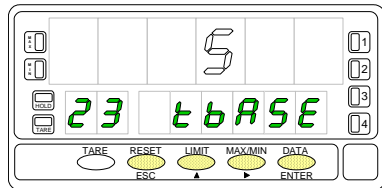

[47.3] Time Base



23 tbASE. Programming the time base.

There are four time bases: **-S-** seconds, **-M-** minutes, **-H-** hours and **-d-** days.



Use  to shift around the available options until the display shows the indication corresponding to the desired time base.

-  Validate the choice and go to the next program phase.
-  Cancel this routine and return to the "-Pro-" stage.

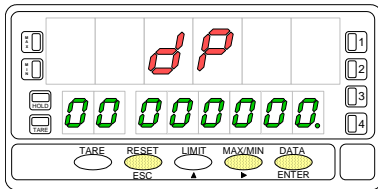
[48.1] Decimal Point





The totalizer decimal point is programmed in the second display and can be located in any of its 8 digits. In this step, the main display shows the indication "dP" and the second display shows the decimal point in flash. Press repeatedly the  key to move it to the desired location. If no decimal point is required, it must be placed to the right of the least significant digit, see figure 48.1.

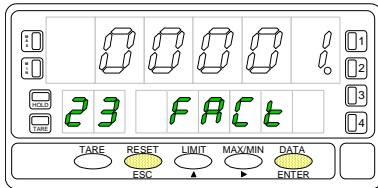

-  Validate the choice and go to the next program phase.
-  Cancel this routine and return to the "-Pro-" stage.

[48.2] Scale Factor



"23 FACT". Programming the scale factor.



Press repeatedly the  key to increment the active digit and press the  key to move to the next digit to the right until the desired scale factor value is completed on the display. A press of  to validate the entry makes the decimal point go in flash. The factor decimal point position is independent from the one of the display, so it is possible to program any value within the range 0.0001 to 09999. It is not possible to set the scale factor to 0.

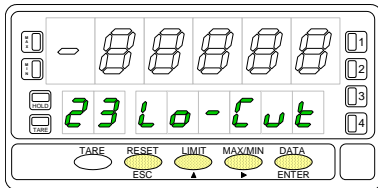

-  Validate the entry and go to the next program phase.
-  Cancel this routine and return to the "-Pro-" stage.

[48.3] Low-Cut Display



"Low-Cut" is the value below which the display is not added to the totalizer.

Press repeatedly the  key to increment the active digit and press the  key to move to the next digit to be modified until desired value is completed on the display. The leftmost digit is used to set the sign ["0" = positive, "-" = negative].

-  Validate the entry, exit from this routine and go to the "-Pro-" stage.
-  Cancel this routine and return to the "-Pro-" stage.

4.3. Display Options, Filters and Round

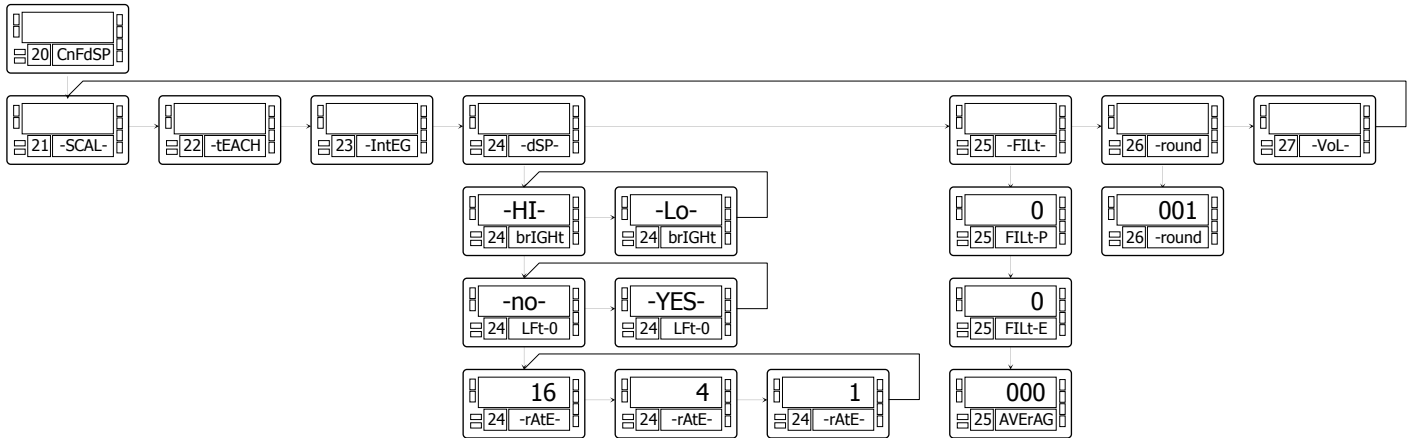

The instrument has several types of digital filtering to provide stable readings according to the nature of the input.

The P filter is a programmable low pass filter that smooths the response of the display to input variations.

The E filter cuts off the signal variations exceeding from the limits of a band. When the input stabilizes, the band moves to the new value.

The Average filter averages the reading over a programmable number of conversions to be displayed at the selected rate.

The round option allows eliminating display jitter by rounding off the meter display by increments of 1, 2, 5, 10, 20, 50 or 100 counts.

In addition, the instrument offers various options so that the user can adjust the reading of the display to meet the system environment conditions, such as selection of two display intensity levels, non-significant zeros (left zeros) and three display update rates.

Menu 24 - DISPLAY OPTIONS

This menu allows configuring various options related to the display visualization; the digit brightness, left zeros and display update rate.

[50.1] Access to the Menu

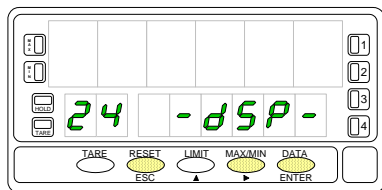



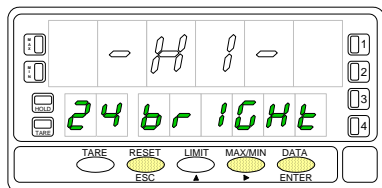



Figure 50.1 shows the indication corresponding to the entry level to display options menu. The following actions are available at this stage:



-  Access to the display options parameters.
-  Skip this menu and pass to the filtering setup menu (p. 49).
-  Exit from this routine and return to the -Pro- stage.

[50.2] Digit Brightness



Menu 23 brIGht. Select digit brightness.

Use the  key to change the display brightness (current choice is noticed each time it is changed). Select "-HI-" or "-LO-" as desired and:

-  Validate the choice and go to the next step.
-  Cancel this routine and return to the -Pro- stage.

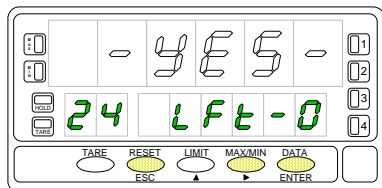

[50.3] Left Zeros



Menu 23 Lft-0. Select non-significant zeros.

There are two options. Select "-YES-" to read the measured value with all the digits of the display by adding left zeros or select "-NO-" to blank non-significant digits.

Use the  key to set desired option and:

-  Validate the choice and go to the next step.
-  Cancel this routine and return to the -Pro- stage.

[51.1] Reading Rate

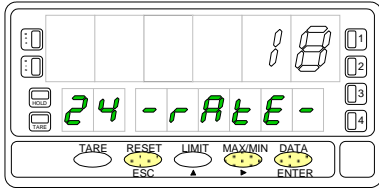

Menu 23 -rAtE-. Select reading rate.

The reading rate determines the rate at which the display is updated. This parameter affects the display, the setpoints, the analog output and the BCD output. Available values are 18, 4 and 1 per second. Press  to select desired rate. Lower levels produce slower display responses to signal changes. The 16 readings/s option will update the display at the rhythm of the signal conversion.

For temperature configurations the effective rate is half the selected number of readings/s.

 Validate the choice and return to the "-Pro-" stage.

 Cancel the programming and go to the "-Pro-" stage.

Menu 25 - DIGITAL FILTERS

If the display reading is unstable due to small signal variations or noise, the use of digital filters may help to reduce these effects and eliminate display jittering. The filter-E parameter only appears for process, load cell or potentiometer inputs.

[52.1] Access to the Menu

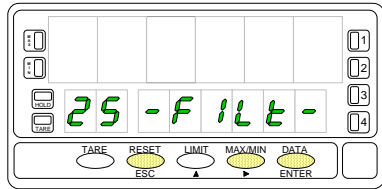

The figure 52.1 represents the access level to menu 25 -FILt-. At this stage, you can use one of the following keys:

- To enter the first step of the menu.
- To skip this menu and pass to the menu 26 -round.
- To cancel this routine and return to the "-Pro-" stage.

[52.2] Filter-P Level

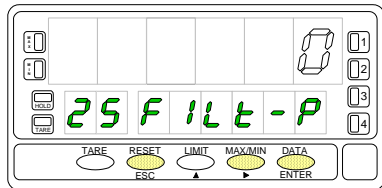

Menu 24 FILt-P. Set filter P level.

The P filter acts as a delay on the display response to signal variations produced at the input. The effect of incrementing this filter level results in a softer response of the display to the input variations. Select filter level from 0 (filter disabled) to 9 using the key.

- Validate changes and advance to the next step.
- Cancel this routine and return to the "-Pro-" stage.

[52.3] Filter-E Level

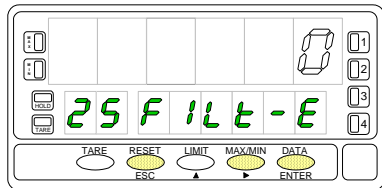

Menu 24 FILt-E. Set filter E level.

The E filter cuts off input variations exceeding from the limits of a moving band. This band becomes more selective as the filter level is increased. Select filter level from 0 (filter disabled) to 9 using the key.

- Validate changes and advance to the next step.
- Cancel this routine and return to the "-Pro-" stage.

[53.1] Average Filter

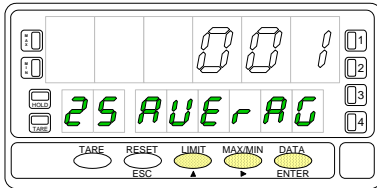

Menu 24 AVErAG. Program n° of readings to average.

This value represents the number of readings that are summed up together and averaged before the display is updated.

Use the ▲ (change value) and ► (change digit) keys to program the desired value from 1 to 200.

ENTER Validate all changes in this menu and return to the -Pro- stage.

ESC Exit this step and return to the -Pro- stage.



Menu 26 - ROUND (process, load cell and potentiometer)

This menu allows selection among six levels of display rounding. When resolution is not critical, a rounding increment other than 1 may help stabilize the display.

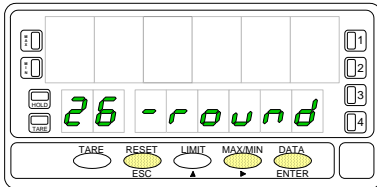
[54.1] Access



The figure 54.1 shows the indication corresponding to the access to the round menu. Press one of the following keys:

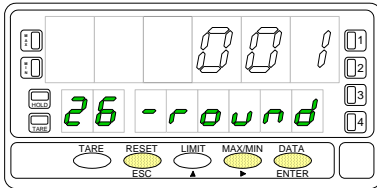

-  To get access to this menu.
-  To skip this menu and pass to the menu 27 -VoL.
-  To cancel this menu and return to the "-Pro-" stage.

[54.2] Round value



Menu 26 -round. Select rounding increment.

Press repeatedly the  key to scroll through available options for the round filter ["001" = no rounding, "005" = round to 5 counts, "010" = round to 10 counts, "020" = round to 20 counts, "050" = round to 50 counts or "100" = round to 100 counts].

-  Validate changes and return to the "-Pro-" stage.
-  Exit this step and return to the "-Pro-" stage.

4.4. Display Volume based on Pressure

There are several methods to calculate the volume of a fluid in a tank.

If a pressure sensor is placed in the bottom of the tank, the display may be scaled to convert the sensor's pressures into liquid height.

The Beta-M provides different approaches to calculate liquid volume.

1. For some special regular tank shapes, if you know the mathematical relationship between pressure and volume, it will only be necessary to scale the display by two points. For example, for a cylindrical vertical tank, volume is the product of the cylinder base area and the liquid height.

2. If the tank is irregularly shaped, you can use the linearization feature to readout volume utilizing the método teach y linealización por tramos.

The method consists of filling the tank with known amounts of liquid, teach the input and enter the volume at each of the selected points over the height of the tank. The more the number of points used, the more accurate the measurement will be.

3. A third method that offers the instrument to extract volume is to set the automatic volume calculation function. This function can be used when the tank's shape correspond to one of the figures represented at right.

Automatic Volume Calculation

The instrument has most common tank geometry functions pre-programmed to calculate volume; spherical, horizontal cylinder, horizontal cylinder with spherical ends and conical bottom vertical cylinder. The user only has to enter the tank dimensions as requested in the program routine.

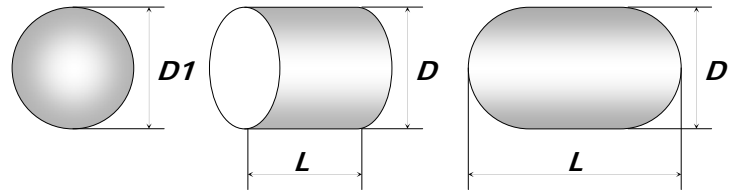

Typ 1 - Sphere

Typ 2 - Cylinder

Typ 3 - Sphere+Cylinder

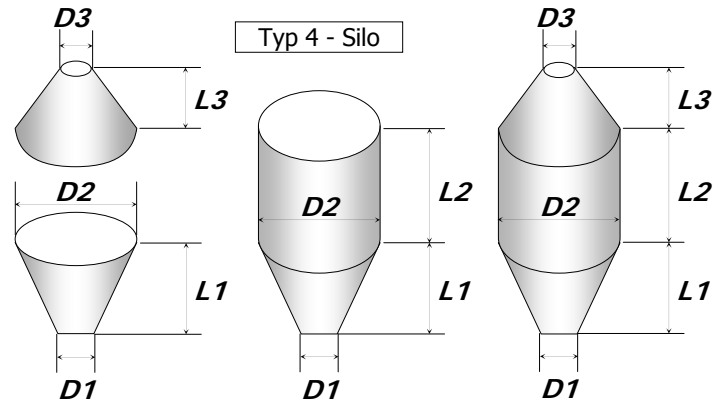

Typ 4 - Silo

Programming Diagram

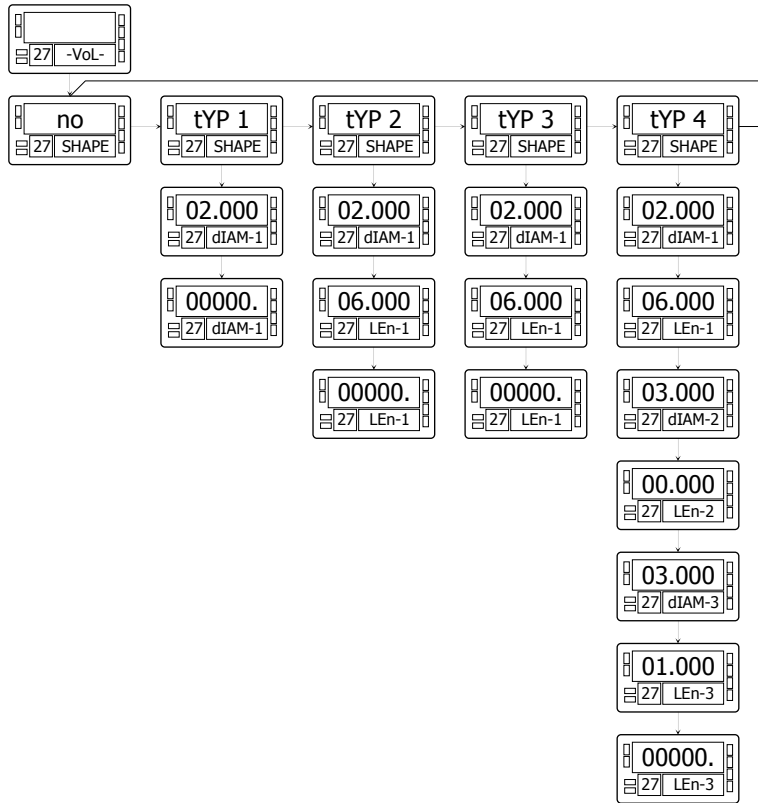

Programming Procedure to Readout Volume

When using this method to display volume, a pressure sensor must be placed at the bottom of the tank to drive a signal proportional to fluid level.

The first scaling phase is to convert the input signal to display height in meters. The height measurement is subsequently used to calculate volume.

The relation between pressure and height is linear, so two scaling points are enough to define the scale. The decimal point position must be chosen so that the display values are expressed in meters, for example, if the fluid level on top scale is 1.5m, suitable programmings would be 0001.5, 001.50, 01.500 or 1.5000 depending on desired resolution.

Once the signal is scaled to measure level in meters, the second phase is to activate the option 'VOL' to display volume. This option is enabled by selecting one of the available tanks shapes (see figure). After this, you must enter the diameter and length of the tank in meters, and finally set the decimal point of the display, which is independent from the decimal point programmed in the scaling procedure.

Volume is expressed in whole liters despite of the point position.



Menu 27 - AUTOMATIC VOLUME CALCULATION

This menu appears exclusively for process and potentiometer configurations. **It is not possible to enable this option if the integrator is active (menu 23).** The automatic volume calculation facility can be only used when the tank's shape is one of the pre-programmed shapes shown in page 55.

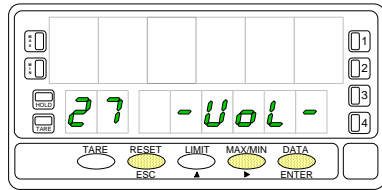
[57.1] Access to the Menu



The figure 57.1 shows the indication "27 -VoL-" corresponding to the input stage of the automatic volume calculation menu.
Use one of the following keys:

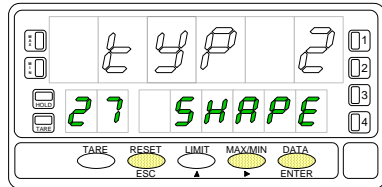

-  To get access to this menu.
-  To pass to the Pasar al Submenú 21 - SCAL.
-  To cancel the programming and return to the "-Pro-" stage.

[57.2] Tank's Shape





Selection of the tank's shape. There are five options: **-no-** to disable this facility, **-tYP 1-** for spherical shape, **-tYP 2-** for horizontal cylinder, **-tYP 3-** for horizontal cylinder with end caps and **-tYP 4-** for conical bottom vertical cylinder (silo).
See figures in page 55.

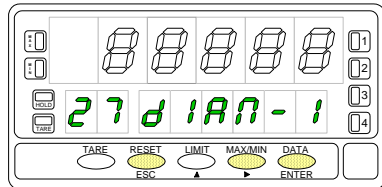

Press  to choose the most appropriate shape from the list (or set the option **-no-** to disable volume calculation).

-  Validate the choice and advance to the next programming phase.
-  Cancel this routine and return to the "-Pro-" stage.

[57.3] Diameter 1





After selecting the tank's shape, it is necessary to enter the dimensions of the tank. Figure 57.3 shows the phase corresponding to the programming of the diameter D1. Press repeatedly the  key to set the active digit to the desired value and  to move one digit to the right until the value for the diameter D1, in meters is completed on the display (the digits to the right of the decimal point are fractions of meter).

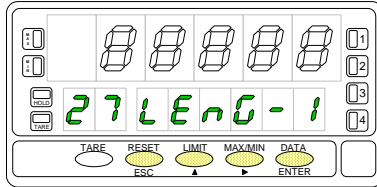

-  Validate the entry and advance to the next programming phase.
-  Cancel this routine and return to the "-Pro-" stage.

[58.1] Length 1



If you selected the spherical shape (tYP 1), this item does not appear. Please, go to the phase represented by figure 58.2.

For the other shapes program the length L1 (see figures in page 55) by using  to increment digit value and  to move to next digit until completing the desired value in meters (the decimal point notation marks the position of whole meters).

-  Validate the entry and advance to the next programming phase.
-  Cancel the programming and return to the "-Pro-" stage.

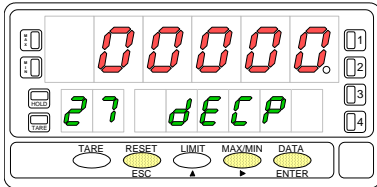

SILO: The silo shape (tYP 4) is a combination of three parts and requires three diameters and three lengths to be programmed. You may have a tank that is composed of only one or two of the parts in which this shape is divided, according to figures on page 55. To overcome this situation, the length of the missing parts should be programmed to zero. The last phase of this routine is to set the decimal point of the display, go to figure 58.2.

[58.2] Decimal Point



After programming the tank dimensions, the display goes to all zeros with the decimal point in flash. This is the decimal point of the volume display, which is independent of that programmed in the scaling routine.

Shift the decimal point to the desired position using . If no decimal point is required, locate it to the rightmost digit.

-  Validate the entry and go to the "-Pro-" stage.
-  Cancel the programming and return to the "-Pro-" stage.

5. FRONT-PANEL AND LOGIC INPUT FUNCTIONS

5.1 - Front-panel functions

The meter provides the following function keys: TARE, RESET, LIMIT and MAX/MIN. The functionality of each one in the "RUN" mode is described below.

TARE key

A push of the TARE key causes the current display to be stored in the tare memory.

The TARE LED denotes that a tare value other than zero is contained in the memory. The tare value (or offset for a temperature meter) can be displayed on the second display by pressing the **MAX/MIN** key.

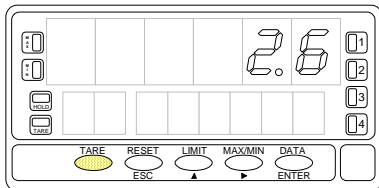

To clear the tare memory, press and hold the **RESET** key, then press **TARE**. Release first **TARE**, then **RESET**. If a tare or tare reset operation is impossible from the front-panel, check the tare key lock settings (see page 67).

LIMIT key

During the RUN mode, this key is only operative in case that one of the following output options is installed: 2 relays (ref. 2RE), 4 relays (ref. 4RE), 4 NPN transistors (ref. 4OP) or 4 PNP transistors (ref. 4OPP).

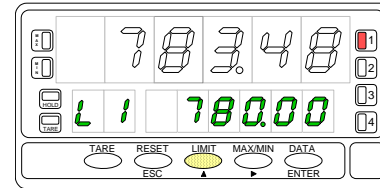

The setpoint programmed values appear on the second display at each push of the **LIMIT** key independently of whether they are enabled or inhibited. The auxiliary display shows L1, L2, L3 or L4 depending of which value is being read.

During the setpoints routine, the functionality of the rest of the keys remains active.

DIGITAL PANEL INSTRUMENT

MODEL TYP9180

Index

1 - Beta-M model overview	6 - 7
1.1 Mode RUN: front-panel description.....	8
1.2 Mode PROG: front-panel description.....	9
2 - Getting started.....	10
2.1 Power and connectors	11 - 12
2.2 Programming instructions	13 - 14
2.3 Programming guide.....	15
3 - Programming module 10. Input configuration diagram	16 - 17
3.1 Program process input. Menu 11.....	18 - 20
3.1.1 Connections (V, mA)	21 - 22
3.2 Program load cell input. Menu 12.....	23 - 24
3.2.1 Connections (mV/ V)	25
3.3 Program Pt100 input. Menu 13	26 - 27
3.3.1 Connections	28
3.4 Program thermocouple input. Menu 14.....	29 - 31
3.4.1 Connections (J, K, T, R, S, E).....	32
3.5 Program potentiometer input. Menu 15	33
3.5.1 Connections.....	33

DIGITAL PANEL INSTRUMENT

MODEL TYP9180

4 - Programming module 20. Display configuration diagram	34 - 35
4.1 Scaling. Menus 21 and 22.....	36 - 45
4.2 Integrator. Menu 23.....	46 - 48
4.3 Display options, Filters and Round	49
4.3.1 Display options. Menu 24	50- 51
4.3.2 Filters. Menu 25.....	52 - 53
4.3.3 Round. Menu 26	54
4.4 Automatic volume calculation. Menu 27	55 - 58
5 - Front-panel functions and remote inputs	
5.1 Front-panel functions	59 and 65
5.2 Remote inputs	66
5.2.1 Table of remote input logic functions	67 - 69
5.2.2 Program remote input logic functions.....	70
6 - Programming parameters lockout.....	71
6.1 Lockout routine.....	72
7 - Output options.....	73 - 74
8 - Technical specifications	75 - 76
8.1 Dimensions and mounting	77
9 - Warranty	78
10 - Declaration of conformity	2
ANNEXES. Index.....	82

MAX/MIN key

Recalls the following parameters to the second display : first push recalls peak, second push recalls valley, third push recalls tare (or offset). If the integrator option is enabled, the fourth push recalls total and, if not enabled but the logic function n°30 (totalizer+batch) is programmed to one of the user inputs a new push shows the number of batch operations. The last push after this sequence blanks the lower displays.

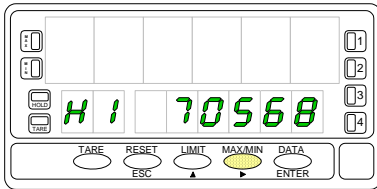

The auxiliary display indicates which variable is being read in the second display : "HI" = peak, "Lo" = valley, "tA" = tare, "oF" = offset, "bA" = n° of batches. The total value needs all 8 digits to be displayed.

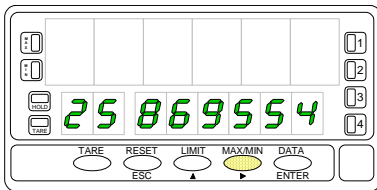

Any selected parameter is permanently displayed and continuously updated if no action is taken.

TO RESET PEAK, VALLEY, TOTAL or BATCH :

RESET key

Press **MAX/MIN** until desired parameter appears on the second display. This parameter may be peak ('HI'), valley ('Lo'), total (auxiliary digits blank or hi part of the total reading) or number of batch operations ('bA').

When desired variable is being read on the lower displays, hold the **RESET** key and press **MAX/MIN**. Release first **MAX/MIN**, then **RESET**.

A tare or tare reset operation updates automatically the peak and valley readings to the current display value.

ENTER key

A momentary push of the ENTER key gives access to the programming mode.

ENTER key (3s)

Gives access to the program lock-out routine. Hold ENTER for approximately 3s, at the end of which the meter prompts the indication '- - -' to enter the security code.

RESET + ENTER (3s)

A press of 3s of both RESET and ENTER restores the factory settings to the memory of the instrument. Press RESET first, then ENTER and hold both until the indication "StorE" appears on the second display.

5.2 - Logic Functions

The rear connector CN2 provides 4 user programmable opto-coupled inputs that can be operated from external contacts or logic levels supplied by an electronic system. Four different functions may be added to the functions available from the front-panel keys. Each function is associated to one of the CN2 connector pins (PIN 1, PIN 2, PIN 4 and PIN 5) and is activated by applying a falling edge or a low level pulse to the corresponding pin with respect to common (PIN 3). Each pin can be assigned one of the 36 functions listed on the following pages.

Factory Configuration

As shipped from the factory, the CN2 connector allows the TARE, MAX/MIN and RESET operations be made in the same way as from the front-panel keyboard and incorporates one more function: the display HOLD.

If the user programs a '0' (no function) to all input pins, they are automatically set to the default configuration.

CN2 : FACTORY DEFAULT CONFIGURATION

PIN (INPUT)	Function	Number
PIN 1 (INP-1)	RESET	Function n° 7
PIN 2 (INP-2)	HOLD	Function n° 9
PIN 3	COMMON	
PIN 4 (INP-4)	TARE	Function n° 1
PIN 5 (INP-5)	PEAK/VALLEY	Function n° 6

The external electronics (fig.66.2) applied to the CN2 connector must be capable of withstanding 40 V and 20 mA present at all terminals with respect to COMMON. In order to guarantee the electromagnetic compatibility, please refer to the instructions given on page 12.

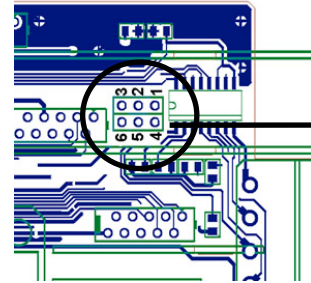

Fig.66.1

CN2 LOGIC
3 2 1 J1



6 5 4 J2

CN2 type of input
PNP J1 (2-3) J2 (5-6)
NPN J1 (1-2) J2 (4-5)

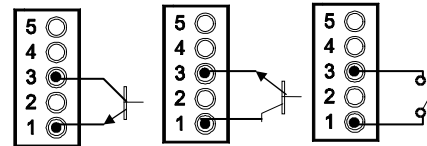

Fig.66.2. Examples of PNP, NPN and contact switch wiring.

5.2.1 - Table of programmable functions

Definition of the column "Action"

Edge : The function is active when a negative edge is applied to the corresponding pin referred to common.

Level : The function is active as long as the corresponding pin is held at a low level with respect to common.

(*) Factory configuration.

0 to 9 : DISPLAY AND MEMORY FUNCTIONS

N°	Name	Function	Action
0	NO	None	-
1	TARE (*)	Adds the current display value to the tare memory	Edge
2	RESET TARE	Clears the tare memory	Edge
3	PEAK	Recalls the peak value	Level
4	VALLEY	Recalls the valley value	Level
5	RESET PEAK/VALLEY	Resets peak and valley readings	Edge
6	VISUAL (*)	Recalls various parameters to the second display; Peak, Valley, Tare or Offset and, if they are active, the Totalizer and the Batch counters. The last action blanks the second display.	Edge
7	RESET (*)	In combination with function (1) clears the tare memory. In combination with function (6) clears the peak or valley memories, or the totalizer or the batch counter	Edge
8	HOLD1	Holds the display	Level
9	HOLD2 (*)	Holds the display and the analog and BCD outputs	Level

10 to 12 : FUNCTIONS ASSOCIATED WITH THE MEASUREMENT DISPLAY

N°	Name	Function	Action
10	INPUT	Displays the signal input value in V or mA, mV or mV from TC or ohms from Pt100	Level
11	GROSS	Displays the gross value (measurement value + tare subtracted)	Level
12	TARE	Displays the value of the tare memory	Level

13 to 16 : FUNCTIONS ASSOCIATED TO THE ANALOG OUTPUT

N°	Name	Function	Action
13	ANA GROSS	The analog output follows the gross value (measured value + tare).	Level
14	ANA ZERO	Puts the analog output to the zero state (0V or 4mA)	Level
15	ANA PEAK	The analog output follows the peak value	Level
16	ANA VALLEY	The analog output follows the valley value	Level

17 to 23 : PRINT FUNCTIONS TO USE WITH RS232C or RS485 OUTPUTS

N°	Name	Function	Action
17	PRINT NET	Prints the net value	Edge
18	PRINT GROSS	Prints the gross value	Edge
19	PRINT TARE	Prints the value of the tare	Edge
20	PRINT SET1	Prints the value and the state of the setpoint 1	Edge
21	PRINT SET2	Prints the value and the state of the setpoint 2	Edge
22	PRINT SET3	Prints the value and the state of the setpoint 3	Edge
23	PRINT SET4	Prints the value and the state of the setpoint 4	Edge

24 to 25 : FUNCTIONS ASSOCIATED WITH THE SETPOINT OUTPUTS

N°	Name	Function	Action
24	FALSE SETPOINTS	Allows programming and operation of four setpoints without setpoint card installed	Level
25	RESET SETPOINTS	Unlocks the setpoint latched outputs	Edge

26 to 36 : SPECIAL FUNCTIONS

N°	Name	Function	Action
26	ROUND RS	Makes the serial output transmit the internal display value, without filters nor rounding	Level
27	ROUND BCD	Makes the BCD output drive out the display value without rounding	Level

26 to 36 : SPECIAL FUNCTIONS (cont.)

Nº	Name	Function	Action
28	ASCII	Send the display last four digits to a Micra-S indicator	Edge
29	SETS INHIBIT	Suspends setpoint operations and keeps the outputs to their OFF state	Level
30	BATCH	Adds the current display value to the totalizer and increments the batch counter in one unit. If the integrator is enabled (menu 23), this function does not work	Edge
31	VIEW TOTAL	Calls the totalizer value to the second display	Level
32	VIEW BATCH	Calls the batch counter to the second display	Level
33	RESET TOTAL+BATCH	Resets the totalizer and the batch counter	Edge
34	STOP TOTAL	Inhibits the integrator operation	Level
35	PRINT TOTAL+BATCH	Prints out the totalizer value and the batch counter value. If the integrator is enabled, only the totalizer value is printed.	Edge
36	PRINT PEAK	Hold and print max reading. When this function is programmed the peak value detection is stopped. In the activation edge, the peak register is cleared from the memory and the unit starts reading new peak values. In the deactivation edge, the peak value registered during the time the function was active is printed out through the serial output	Level

5.2.2 - Program the logic functions

Press **ENTER** to enter in the programming mode (-Pro- level) and press repeatedly **▶** until the indication shown in figure 70.1 appears on the display. From this stage press **ENTER** to access the logic inputs configuration. The **▶** key rotates around the four logic inputs to view the function number assigned to each pin. The **▲** key changes the number if desired.

To program the logic inputs follow the procedure described below for input 1.

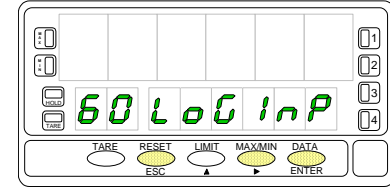
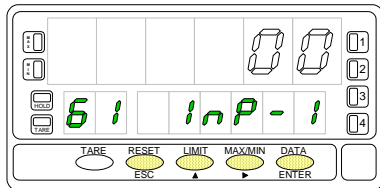

Fig. 70.1: Logic inputs configuration module

Menu 61 - Program Logic Input 1

[70.2] Logic input PIN 1



Menu 61 Inp-1. Assign logic function to PIN 1.

The main display shows the function number assigned to logic input 1. Refer to the table to select function and use the **▲** key to change the number if desired.

- ▶** Pass to the programming of the following logic input.
- ENTER** Validate changes and return to the -Pro- stage.
- ESC** Exit from this menu and go to the -Pro- stage.

6. PARAMETER LOCKOUTS

The instrument is supplied with all software programming parameters accessible to operator's modifications. After completing the software configuration, it is recommended to take the following steps:

1. Lockout programming parameters to prevent from accidental or unauthorized modifications.
2. Lockout the tare key operation.
3. The lockout can be applied to everything or to specific menus or parameters. If some parameters should be reprogrammed frequently, make a partial lock leaving such parameters accessible. If no subsequent adjust must be made, make a total lock.
4. The access to the lockout routine is allowed by entering a safety code. At fabrication this code is set to 0000. We recommend to change this code and to write it down and keep safe.
5. Prior to configure the meter, it is recommended to organize all data and keep a record s manual.

TOTAL LOCKOUT

The access to the programming routines to read data is allowed even if all parameters are locked out, but **it won't be possible to enter or modify data**. In this case, when entering in the programming mode, the second display shows the indication -dAtA- instead of -Pro-.

SELECTIVE LOCKOUT

When only some parameters are locked out, all configuration data can be read but **only non-protected parameters can be modified**. In such case, when entering in the programming mode, the second display shows the indication -Pro-.

Selective lock-outs include the following groups:

- Setpoint 1 configuration (menu 31).
- Setpoint 2 configuration (menu 32).
- Setpoint 3 configuration (menu 33).
- Setpoint 4 configuration (menu 34).
- Input configuration (module 10).
- Scaling (menus 21/22, 23 and 27).
- Display options and filtering (menus 24, 25 and 26).
- Analog output configuration (module 40).
- Serial output configuration (module 50).
- Logic inputs configuration (module 60).
- Direct access to the programming of the setpoint values

Those that refer to optional outputs only appear if the corresponding option is installed.

6.1 - Lockout programming routine

The lock-out programming routine is entered by depressing the **ENTER** key for 3 seconds and introducing a security code. This gives access to either the parameter list or to change the code if desired.

If the user opts for changing the code, the unit asks for the new one and returns to the normal operation. The old code is replaced with the user selected one, that will be asked next time this routine is entered.

When the user enters the parameter list, each parameter is indicated in the second display, while in the first one a blinking digit allows setting a '1' to lock this item, or a '0' to free it.

There are two ways to lock-out the program; One is to lock everything, which is accomplished by setting a '1' in the 'tot-LC' parameter (the remaining parameters are skipped except the tare key lock).

The second is to individually lock some parts of the program menus leaving free those parts which are more liable to have changes during normal operation.

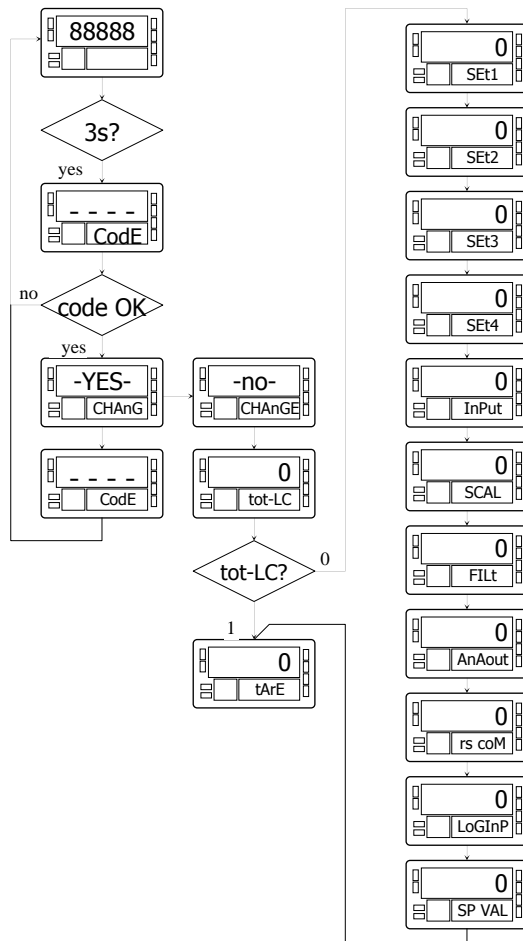

7. OUTPUT OPTIONS

Output options with instructions manual edited before December 1999, work properly with new versions of TYP9180 but some new features may not be described in the options manual.

If you are using an older output card connected to a new TYP9180 and you want to take benefit of the new functions (see page 60), please call for an updated edition of the options manual.

Optionally, model BETA-M can incorporate one or several output options for communications or control including :

COMMUNICATION

9180-Vxx1x	Serial RS232C
9180-Vxx2x	Serial RS485
9180-Vxx3x	BCD 24V/TTL

CONTROL

9180-Vx1xx	Analogue 4-20 mA, 0-10 V
9180-Vxxx1	2 SPDT relays 8 A
9180-Vxxx2	4 SPST relays 5 A
9180-Vxxx3	4 open-collector NPN outputs
9180-Vxxx4	4 open-collector PNP outputs

All options are optoisolated with respect to the input signal.

The options are supplied with a specific instructions manual describing characteristics, installation, connections and programming. The output cards are easily installed on the meter's main board by means of plug-in connectors and each one activates its own programming module that provides complete software-configuration.

Additional capabilities of the unit with output options :

- Control and processing of limit values via ON/OFF logic outputs (2 relays, 4 relays, 4 NPN outputs or 4 PNP outputs) or proportional output (4-20 mA or 0-10 V).
- Communication, data transmission and remote programming via serial interface.

For more detailed information on characteristics, applications, mounting and programming, please refer to the specific manual supplied with each option.

The figure shows the main circuit board locations of the available output options. Each plug-in location can accept only one card from a particular function type.

The options 9180-Vxxx1, 9180-Vxxx2, 9180-Vxxx3 and 9180-Vxxx4 are for setpoint control and only one of them can be installed in the M5 location.

The options 9180-Vxx1x and 9180-Vxx2x are for communication and only one of them can be installed in the M1 location.

The 9180-Vx1xx option provides selectable 0-10V and 20mA analog output and is installed in the M4 location.

Up to three output options can be present at a time and operate simultaneously:

- ANALOGUE, 0-10V or 4-20mA
- RS232C or RS485 (one of them),
- 2 RELAYS, 4 RELAYS or 4 NPN or 4 PNP outputs (one of them).

The 9180-Vxx3x output is exclusive and it does not allow any of the others. This option is attached to the main circuit board by means of a 18-pin FLAT cable.

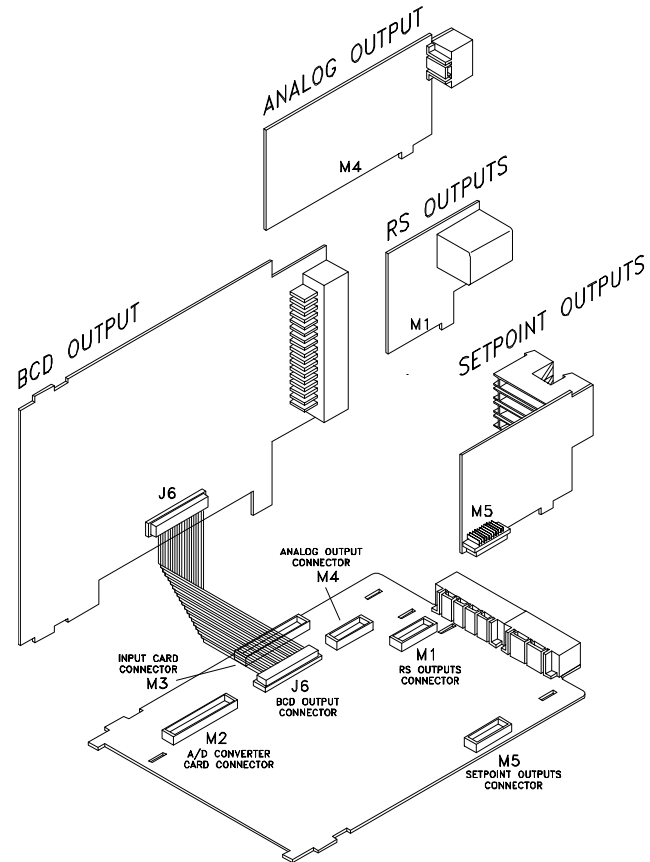

8. TECHNICAL SPECIFICATIONS

INPUT SIGNAL

- Configuration differential asymmetrical

Process input	Voltage	Current
• Voltage	$\pm 10\text{V DC}$	$\pm 20\text{mA DC}$
• Max. resolution.....	0.1mV	$1\mu\text{A}$
• Input impedance	$1\text{M}\Omega$	15Ω
• Excitation	$24\text{V (30mA), 10/ 5V (120mA)}$	
• Max error	$\pm (0.1\% \text{ of the reading} + 3 \text{ digits})$	
• Temperature coefficient	$100 \text{ ppm/ } ^\circ\text{C}$	

Load cell input

- Voltage $\pm 300 \text{ mV DC}$
- Max. resolution..... $0.15 \mu\text{V}$
- Input impedance $100 \text{ M}\Omega$
- Excitation $10/ 5\text{V (120 mA)}$
- Max error $\pm (0.1\% \text{ of the reading} + 6 \text{ digits})$
- Temperature coefficient $100 \text{ ppm/ } ^\circ\text{C}$

Potentiometer input

- Voltage $\pm 10\text{V DC}$
- Input impedance $1\text{M}\Omega$
- Display resolution 0.001%
- Max error $\pm (0.1\% \text{ of the reading} + 3 \text{ digits})$
- Temperature coefficient $100 \text{ ppm/ } ^\circ\text{C}$

Temperature input

- Cold junction compensation..... $-10 ^\circ\text{C to } +60 ^\circ\text{C}$
- Cold junction $\pm(0.05 ^\circ\text{C/ } ^\circ\text{C} + 0.1 ^\circ\text{C})$
- Pt100 excitation current $< 1 \text{ mA DC}$
- Max. cable resistance $40 \Omega/ \text{ cable (balanced)}$
- Temperature coefficient $100 \text{ ppm/ } ^\circ\text{C}$

Input	Range (0.1 ^o)	Accuracy (0.1 ^o)	Range (1 ^o)	Accuracy (1 ^o)
TC J	-200.0 to +1100.0 °C	0.4% L $\pm 0.6 ^\circ\text{C}$	-200 to +1100 °C	0.4% L $\pm 1 ^\circ\text{C}$
	-328.0 to +2012.0 °F	0.4% L $\pm 1 ^\circ\text{F}$	-328 to +1472 °F	0.4% L $\pm 2 ^\circ\text{F}$
TC K	-200.0 to +1200.0 °C	0.4% L $\pm 0.6 ^\circ\text{C}$	-200 to +1200 °C	0.4% L $\pm 1 ^\circ\text{C}$
	-328.0 to +2192.0 °F	0.4% L $\pm 1 ^\circ\text{F}$	-328 to +2192 °F	0.4% L $\pm 2 ^\circ\text{F}$
TC T	-150.0 to +400.0 °C	0.4% L $\pm 0.6 ^\circ\text{C}$	-150 to +400 °C	0.4% L $\pm 1 ^\circ\text{C}$
	-302.0 to +752.0 °F	0.4% L $\pm 1 ^\circ\text{F}$	-302 to +752 °F	0.4% L $\pm 2 ^\circ\text{F}$
TC R	-50.0 to 1700.0 °C	0.5% L $\pm 2 ^\circ\text{C}$	-50 to 1700 °C	0.5% L $\pm 4 ^\circ\text{C}$
	-58.0 to +3092.0 °F	0.5% L $\pm 4 ^\circ\text{F}$	-58 to +3092 °F	0.5% L $\pm 7 ^\circ\text{F}$
TC S	-50.0 to 1700.0 °C	0.5% L $\pm 2 ^\circ\text{C}$	-50 to 1700 °C	0.5% L $\pm 4 ^\circ\text{C}$
	-58.0 to +3092.0 °F	0.5% L $\pm 4 ^\circ\text{F}$	-58 to +3092 °F	0.5% L $\pm 7 ^\circ\text{F}$
TC E	-200.0 to 1000.0 °C	0.4% L $\pm 1 ^\circ\text{C}$	-200 to 1000 °C	0.4% L $\pm 2 ^\circ\text{C}$
	-328.0 to +1832.0 °F	0.4% L $\pm 2 ^\circ\text{F}$	-328 to +1832 °F	0.4% L $\pm 4 ^\circ\text{F}$
Pt100	-100.0 to +800.0 °C	0.2% L $\pm 0.6 ^\circ\text{C}$	-100 to +800 °C	0.2% L $\pm 1 ^\circ\text{C}$
	-148.0 to +1472.0 °F	0.2% L $\pm 1 ^\circ\text{F}$	-148 to +1472 °F	0.2% L $\pm 2 ^\circ\text{F}$

ELECTRICAL SAFETY

- Installation category II
- Degree of pollution 2

FUSES (DIN 41661) - Not supplied

- Beta-M (230/115V AC) F 0.2 A / 250 V
- Beta-M2 (24/48V AC) F 0.5 A / 250 V

A/D CONVERSION

- Technique Sigma-Delta
- Resolution (24 bit)
- Rate 18/s

ACCURACY at 23° ± 5° C

- Temperature coefficient 100 ppm/ °C
- Warm-up time 10 min

POWER SUPPLY

- AC voltages 230/115 V, 24/48 V (±10%) 50/60 Hz AC
- Consumption 5W (without options), 10W (max)

DISPLAY

- Main -99999/ +99999, 6 digits red LED 14 mm
- Secondary 6 digits green LED 8 mm
- Auxiliary 2 digits green LED 8 mm
- Decimal point programmable
- LEDs 4 functions and 4 output status
- Reading rate 55.5 ms/ 250 ms/ 1 s
- Positive overrange oVFLo
- Negative overrange -oVFLo
- Sensor Break "-----"

ENVIRONMENTAL

(indoor use)

- Operating temperature -10 °C to +60 °C
- Storage temperature -25 °C to +85 °C
- Relative humidity <95 % at 40 °C
- Max. altitude 2000 meters

MECHANICAL

- Dimensions 96x48x120 mm
- Panel cutout 92x45 mm
- Weight 600 g
- Case material UL 94 V-0 rated polycarbonate

8.1 - Dimensions and mounting

To mount the instrument into the panel, make a cutout of 92x45mm. Slide the sealing gasket over the instrument's case to the bezel and insert the instrument through the panel cutout from the front.

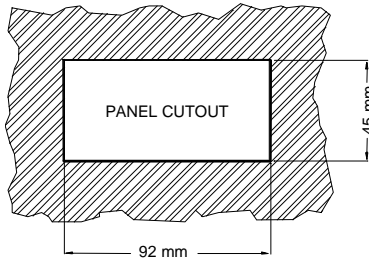

Place the fixing clips on both sides of the case and push them over the rear until they touch the panel. Apply pressure to engage the tabs on the fixing clips to the slots of the case.

To remove the instrument from the panel, pull outwards the fixing clips from the rear tabs to disengage and slide them back over the case.

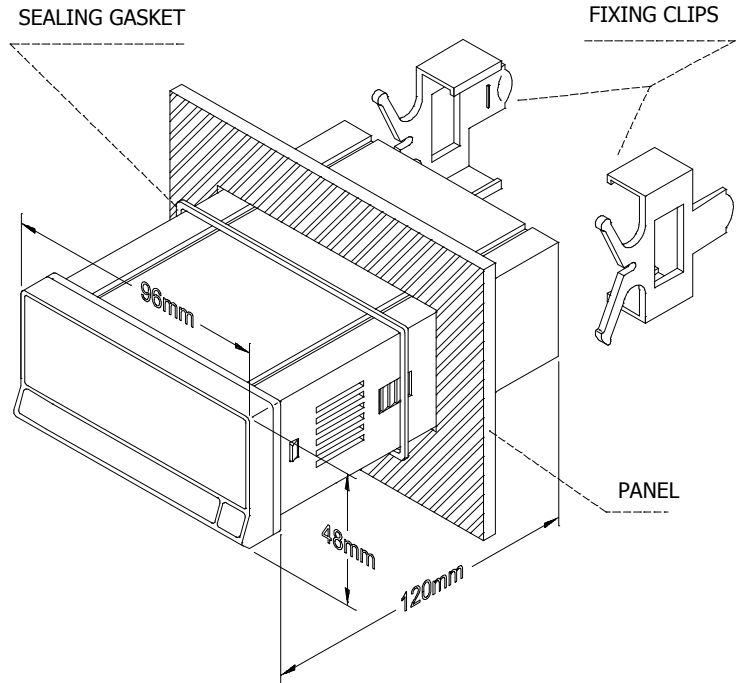

CLEANING: The front cover should be cleaned only with a soft cloth soaked in neutral soap products. DO NOT USE SOLVENTS

9. WARRANTY

All products are warranted against defective material and workmanship for a period of three years from date of delivery.

If a product appears to have a defect or fails during the normal use within the warranty period, please contact the distributor from whom you purchased the product.

This warranty does not apply to defects resulting from action of the buyer such as mishandling or improper interfacing.

The liability under this warranty shall extend only to the repair of the instrument; no responsibility is assumed by the manufacturer for any damage which may result from its use.

ANNEXES

MODEL TYP9180

Index

SECTION	Page
ANNEXE A. SETPOINTS	83
ANNEXE B. SERIAL OUTPUTS RS232C AND RS485	
B.1. List of Commands	84 to 85
B.2. Address of the Variables in the memory	86 to 103
ANNEXE C.	
c1. TARE MODE	105 to 106
c2. Sensor break	107
c3. Fail SAFE in Setpoints menu	108
c4. r.o.C. in Setpoints menu	109
c5. doSE function in Setpoints menu	110

ANNEXE A. SETPOINTS

The following functions have been added:

1. Use setpoint 2 to detect max reading

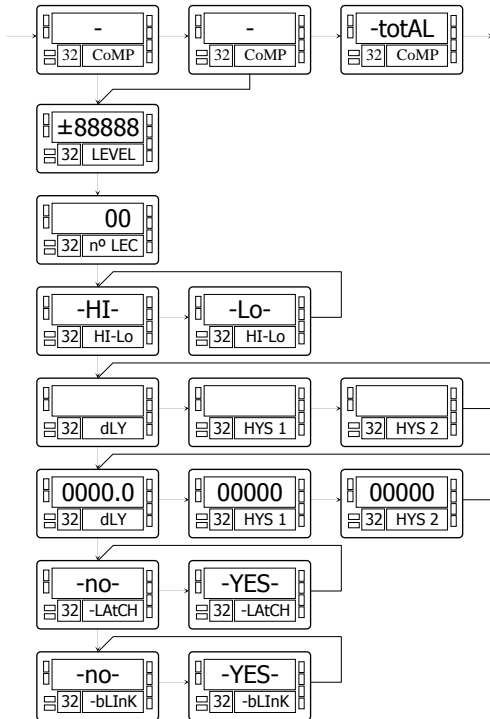

The option 'MAX' is for non-filtered peak values and the option 'MAX-F' is for filtered values.

The setpoint configuration options (latch, HI-LO mode, delay-hysteresis, blink) are programmed as for a standard setpoint but some have different meanings in this case, the setpoint value is the display value from which the unit begins to read peaks, below this value the operation is disabled.

The delay/hysteresis value is the amount of time that the output will stay active from the moment that a peak value is detected (except in mode latch).

The output activation occurs when the instrument detects that the measured variable has stopped increasing its magnitude and is falling down or stable for a number of readings programmable from 0 to 99.

The 'n°-LEC' parameter allows to program the number of readings to wait from the last peak detection, before the input variable can be considered to grow up no more (the instrument makes 16 readings per second).

2. Control the setpoint outputs by a command via RS232C or RS485

This facility is enabled by selecting the option 'CoM' in the setpoint on-off menu level. The rest of the standard setpoint options are omitted in the programming routine except selection of the display blink. The output status of these setpoints cannot be changed by an overflow condition or a pass to the programming mode.

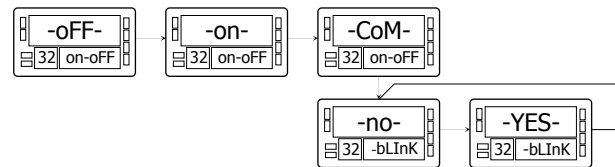

3. The setpoints can be referred to the totalizer value

In this case the setpoint value is programmed in the second display. The rest of the options are the same as for a standard setpoint.

ANNEXE B. SERIAL OUTPUT RS232C or RS485

B.1. List of Commands

REQUEST OF DATA

ASCII	ISO	Information
I	0I	Logic inputs status
P	0P	Peak value
V	0V	Valley value
T	0T	Tare/Offset value
D	0D	Display value
Z	0Z	Totalizer value
X	0X	Batch counter value
L1	L1	Value of the setpoint1
L2	L2	Value of the setpoint2
L3	L3	Value of the setpoint3
L4	L4	Value of the setpoint4
E	0E	Bit 0=input overflow, bit 1= scale overflow, bit 2= Sensor break

MODIFICATION OF DATA

ASCII	ISO	Parameter
M1	M1	Change the setpoint1 value in the memory
M2	M2	Change the setpoint2 value in the memory
M3	M3	Change the setpoint3 value in the memory
M4	M4	Change the setpoint4 value in the memory
S1	S1	Change the setpoint1 value (not stored in memory)
S2	S2	Change the setpoint1 value (not stored in memory)
S3	S3	Change the setpoint1 value (not stored in memory)
S4	S4	Change the setpoint1 value (not stored in memory)

COMMANDS

ASCII	ISO	MODBUS	Command
n	0n	n	Reset latched outputs
p	0p	p	Reset peak
v	0v	v	Reset valley
r	0r	r	Reset tare
t	0t	t	Tare the display
z	0z	z	Reset totalizer
x	0x	x	Reset batch counter
a1	a1	a1	Activate setpoint1
a2	a2	a2	Activate setpoint2
a3	a3	a3	Activate setpoint3
a4	a4	a4	Activate setpoint4
d1	d1	d1	Deactivate setpoint1
d2	d2	d2	Deactivate setpoint2
d3	d3	d3	Deactivate setpoint3
d4	d4	d4	Deactivate setpoint4

B.2. Address of the Variables in the Memory

PROGRAMMING DATA (READ/WRITE)

ISO	MODBUS	Variable	Description		
0	0	INPUT POINT 1	Sign 0=+,A=-		
1			digit 4		
2			digit 3		
3			digit 2		
4			digit 1		
5	1	INPUT POINT 1	digit 0		
6			3	INPUT POINT 2	sign
7					digit 4
8					digit 3
9					digit 2
10	digit 1				
11	4	INPUT POINT 2	digit 0		
12			5	INPUT POINT 3	sign
13					digit 4
14					digit 3
15					digit 2
16	digit 1				
17	6	INPUT POINT 3	digit 0		
18			7	INPUT POINT 4	sign
19					digit 4
20					digit 3
21					digit 2
22	digit 1				
23	8	INPUT POINT 4	digit 0		
24			9	INPUT POINT 5	sign
25					digit 4
26					digit 3
27					digit 2
28	digit 1				
29	10	INPUT POINT 5	digit 0		
29			11	digit 0	
	12	INPUT POINT 5	digit 0		
			13	digit 0	
	14	INPUT POINT 5	digit 0		
			14	digit 0	

30	15	INPUT POINT 6	sign
31			digit 4
32	16		digit 3
33			digit 2
34	17		digit 1
35			digit 0
36	18	INPUT POINT 7	sign
37			digit 4
38	19		digit 3
39			digit 2
40	20		digit 1
41			digit 0
42	21	INPUT POINT 8	sign
43			digit 4
44	22		digit 3
45			digit 2
46	23		digit 1
47			digit 0
48	24	INPUT POINT 9	sign
49			digit 4
50	25		digit 3
51			digit 2
52	26		digit 1
53			digit 0
54	27	INPUT POINT 10	sign
55			digit 4
56	28		digit 3
57			digit 2
58	29		digit 1
59			digit 0
60	30	INPUT POINT 11	sign
61			digit 4
62	31		digit 3
63			digit 2
64	32		digit 1
65			digit 0

66	33	INPUT POINT 12	sign
67			digit 4
68	34		digit 3
69			digit 2
70	35		digit 1
71			digit 0
72	36	INPUT POINT 13	sign
73			digit 4
74	37		digit 3
75			digit 2
76	38		digit 1
77			digit 0
78	39	INPUT POINT 14	sign
79			digit 4
80	40		digit 3
81			digit 2
82	41		digit 1
83			digit 0
84	42	INPUT POINT 15	sign
85			digit 4
86	43		digit 3
87			digit 2
88	44		digit 1
89			digit 0
90	45	INPUT POINT 16	sign
91			digit 4
92	46		digit 3
93			digit 2
94	47		digit 1
95			digit 0
96	48	INPUT POINT 17	sign
97			digit 4
98	49		digit 3
99			digit 2
100	50		digit 1
101			digit 0

102	51	INPUT POINT 18	sign
103			digit 4
104	52		digit 3
105			digit 2
106	53		digit 1
107			digit 0
108	54		INPUT POINT 19
109	55	digit 4	
110		digit 3	
111	digit 2		
112	56	digit 1	
113		digit 0	
114	57	INPUT POINT 20	
115	58		digit 4
116			digit 3
117	digit 2		
118	59		digit 1
119			digit 0
120	60		INPUT POINT 21
121	61	digit 4	
122		digit 3	
123	digit 2		
124	62	digit 1	
125		digit 0	
126	63	INPUT POINT 22	
127	64		digit 4
128			digit 3
129	digit 2		
130	65		digit 1
131			digit 0
132	66		INPUT POINT 23
133	67	digit 4	
134		digit 3	
135	digit 2		
136	68	digit 1	
137		digit 0	

138	69	INPUT POINT 24	sign
139			digit 4
140	70		digit 3
141			digit 2
142	71		digit 1
143			digit 0
144	72	INPUT POINT 25	sign
145	73		digit 4
146			digit 3
147	74		digit 2
148			digit 1
149	digit 0		
150	75	INPUT POINT 26	sign
151	76		digit 4
152			digit 3
153	77		digit 2
154			digit 1
155	digit 0		
156	78	INPUT POINT 27	sign
157	79		digit 4
158			digit 3
159	80		digit 2
160			digit 1
161	digit 0		
162	81	INPUT POINT 28	sign
163	82		digit 4
164			digit 3
165	83		digit 2
166			digit 1
167	digit 0		
168	84	INPUT POINT 29	sign
169	85		digit 4
170			digit 3
171	86		digit 2
172			digit 1
173	digit 0		

174	87	INPUT POINT 30	sign
175			digit 4
176	88		digit 3
177			digit 2
178	89		digit 1
179			digit 0
180	90	DISPLAY POINT 1	sign
181			digit 4
182	91		digit 3
183			digit 2
184	92		digit 1
185			digit 0
186	93	DISPLAY POINT 2	sign
187			digit 4
188	94		digit 3
189			digit 2
190	95		digit 1
191			digit 0
192	96	DISPLAY POINT 3	sign
193			digit 4
194	97		digit 3
195			digit 2
196	98		digit 1
197			digit 0
198	99	DISPLAY POINT 4	sign
199			digit 4
200	100		digit 3
201			digit 2
202	101		digit 1
203			digit 0
204	102	DISPLAY POINT 5	sign
205			digit 4
206	103		digit 3
207			digit 2
208	104		digit 1
209			digit 0

210	105	DISPLAY POINT 6	sign
211			digit 4
212	106		digit 3
213			digit 2
214	107		digit 1
215		digit 0	
216	108	DISPLAY POINT 7	sign
217			digit 4
218	109		digit 3
219			digit 2
220	110		digit 1
221		digit 0	
222	111	DISPLAY POINT 8	sign
223			digit 4
224	112		digit 3
225			digit 2
226	113		digit 1
227		digit 0	
228	114	DISPLAY POINT 9	sign
229			digit 4
230	115		digit 3
231			digit 2
232	116		digit 1
233		digit 0	
234	117	DISPLAY POINT 10	sign
235			digit 4
236	118		digit 3
237			digit 2
238	119		digit 1
239		digit 0	
240	120	DISPLAY POINT 11	sign
241			digit 4
242	121		digit 3
243			digit 2
244	122		digit 1
245		digit 0	

246	123	DISPLAY POINT 12	sign
247			digit 4
248	124		digit 3
249			digit 2
250	125		digit 1
251			digit 0
252	126	DISPLAY POINT 13	sign
253			digit 4
254	127		digit 3
255			digit 2
256	128		digit 1
257			digit 0
258	129	DISPLAY POINT 14	sign
259			digit 4
260	130		digit 3
261			digit 2
262	131		digit 1
263			digit 0
264	132	DISPLAY POINT 15	sign
265			digit 4
266	133		digit 3
267			digit 2
268	134		digit 1
269			digit 0
270	135	DISPLAY POINT 16	sign
271			digit 4
272	136		digit 3
273			digit 2
274	137		digit 1
275			digit 0
276	138	DISPLAY POINT 17	sign
277			digit 4
278	139		digit 3
279			digit 2
280	140		digit 1
281			digit 0

282	141	DISPLAY POINT 18	sign
283			digit 4
284	142		digit 3
285			digit 2
286	143		digit 1
287			digit 0
288	144	DISPLAY POINT 19	sign
289	145		digit 4
290			digit 3
291			digit 2
292	146		digit 1
293			digit 0
294	147	DISPLAY POINT 20	sign
295	148		digit 4
296			digit 3
297			digit 2
298	149		digit 1
299			digit 0
300	150	DISPLAY POINT 21	sign
301	151		digit 4
302			digit 3
303			digit 2
304	152		digit 1
305			digit 0
306	153	DISPLAY POINT 22	sign
307	154		digit 4
308			digit 3
309			digit 2
310	155		digit 1
311			digit 0
312	156	DISPLAY POINT 23	sign
313	157		digit 4
314			digit 3
315			digit 2
316	158		digit 1
317			digit 0

318	159	DISPLAY POINT 24	sign
319			digit 4
320	160		digit 3
321			digit 2
322	161		digit 1
323			digit 0
324	162	DISPLAY POINT 25	sign
325			digit 4
326	163		digit 3
327			digit 2
328	164		digit 1
329			digit 0
330	165	DISPLAY POINT 26	sign
331			digit 4
332	166		digit 3
333			digit 2
334	167		digit 1
335			digit 0
336	168	DISPLAY POINT 27	sign
337			digit 4
338	169		digit 3
339			digit 2
340	170		digit 1
341			digit 0
342	171	DISPLAY POINT 28	sign
343			digit 4
344	172		digit 3
345			digit 2
346	173		digit 1
347			digit 0
348	174	DISPLAY POINT 29	sign
349			digit 4
350	175		digit 3
351			digit 2
352	176		digit 1
353			digit 0

354	177	DISPLAY POINT 30	sign
355	178		digit 4
356			digit 3
357	179		digit 2
358			digit 1
359		digit 0	
360	180	SETPOINT 1	digit 7 / sign
361	181		digit 6
362			digit 5
363	182		digit 4
364			digit 3
365			digit 2
366	183		digit 1
367		digit 0	
368	184	SETPOINT 2	digit 7 / sign
369	185		digit 6
370			digit 5
371	186		digit 4
372			digit 3
373			digit 2
374	187		digit 1
375			digit 0
376	188	SETPOINT 3	digit 7 / sign
377	189		digit 6
378			digit 5
379	190		digit 4
380			digit 3
381			digit 2
382	191		digit 1
383		digit 0	
384	192	SETPOINT 4	digit 7 / sign
385	193		digit 6
386			digit 5
387	194		digit 4
388			digit 3
389			digit 2

390	195		digit 1
391			digit 0
392	196	DELAY / HYSTERESIS SETPOINT 1	digit 4
393			digit 3
394	197		digit 2
395			digit 1
396	198	DELAY / HYSTERESIS SETPOINT 2	digit 0
397			digit 4
398	199		digit 3
399			digit 2
400	200		digit 1
401			digit 0
402	201	DELAY / HYSTERESIS SETPOINT 3	digit 4
403			digit 3
404	202		digit 2
405			digit 1
406	203	DELAY / HYSTERESIS SETPOINT 4	digit 0
407			digit 4
408	204		digit 3
409			digit 2
410	205		digit 1
411			digit 0
412	206	ON-OFF SETPOINT 1	0=off, 1=on, 2=track, 3=rscom
413		ON-OFF SETPOINT 2	0=off, 1=on, 2=track, 3=rscom
414	207	ON-OFF SETPOINT 3	0=off, 1=on, 2=track, 3=rscom
415		ON-OFF SETPOINT 4	0=off, 1=on, 2=track, 3=rscom
416	208	COMP SETPOINT 1	0=net, 1=gross, 2=peak, 3=valley, 6=total
417		COMP SETPOINT 2	0=net, 1=gross, 2=peak, 3=valley, 4=max, 5=max filter, 6=total
418	209	COMP SETPOINT 3	0=net, 1=gross, 2=peak, 3=valley, 6=total
419		COMP SETPOINT 4	0=net, 1=gross, 2=peak, 3=valley, 6=total
420	210	HI-LO SETPOINT 1	0=hi, 1=lo
421		HI-LO SETPOINT 2	0=hi, 1=lo
422	211	HI-LO SETPOINT 3	0=hi, 1=lo
423		HI-LO SETPOINT 4	0=hi, 1=lo
424	212	DELAY-HYST SETPOINT 1	0=delay, 1=hysteresis-1, 2=hysteresis-2
425		DELAY-HYST SETPOINT 2	0=delay, 1=hysteresis-1, 2=hysteresis-2

426	213	DELAY-HYST SETPOINT 3	0=delay, 1=hysteresis-1, 2=hysteresis-2
427		DELAY-HYST SETPOINT 4	0=delay, 1=hysteresis-1, 2=hysteresis-2
428	214	LATCH SETPOINT 1	0=no, 1=yes
429		LATCH SETPOINT 2	0=no, 1=yes
430	215	LATCH SETPOINT 3	0=no, 1=yes
431		LATCH SETPOINT 4	0=no, 1=yes
432	216	BLINK SETPOINT 1	0=LED, 1=LED+blink
433		BLINK SETPOINT 2	0=LED, 1=LED+blink
434	217	BLINK SETPOINT 3	0=LED, 1=LED+blink
435		BLINK SETPOINT 4	0=LED, 1=LED+blink
436	218	TRACK AUTO	0=no, 1=yes
437		N° LINEARIZATION POINTS	2 to 30
438	219	N° READINGS SETPOINT MAX	digit 1
439			digit 0
440	220	ANALOG OUTPUT TYPE	0=Vdc, 1=Idc
441		ANALOG OUTPUT FILTER	0=off, 1=on
442	221	ANALOG OUTPUT HI DISPLAY	sign
443			digit 4
444	222		digit 3
445			digit 2
446	223		digit 1
447			digit 0
448	224	ANALOG OUTPUT LO DISPLAY	sign
449			digit 4
450	225		digit 3
451			digit 2
452	226		digit 1
453			digit 0
454	227	DIAMETER 1 (VOLUME)	digit 4
455			digit 3
456	228		digit 2
457			digit 1
458	229		digit 0
459			LENGTH 1 (VOLUME)
460	230		digit 3

462	231		digit 1
463			digit 0
464	232	DIAMETER 2 (VOLUME)	digit 4
465			digit 3
466	233		digit 2
467			digit 1
468	234		digit 0
469			LENGTH 2 (VOLUME)
470	235		digit 4
471			digit 3
472	236		digit 2
473			digit 1
474	237	DIAMETER 3 (VOLUME)	digit 0
475			digit 4
476	238		digit 3
477			digit 2
478	239		digit 1
479			digit 0
480	240	LENGTH 3 (VOLUME)	digit 4
481			digit 3
482	241		digit 2
483			digit 1
484	242	TANK'S SHAPE	digit 0
485		DECIMAL POINT (VOLUME)	0=no, 1=sphere, 2=cyinder, 3=cylinder+sphere, 4=silo
486	243	EXCITATION	0=88888, 1=8888.8, 2=888.88, 3=88.888, 4=8.8888
487		INPUT TYPE	0=24V, 1=10V
488	244	PROCESS TYPE	0=process, 1=load cell, 2=Pt100, 3=thermocouple, 4=potentiometer
489		THERMOCOUPLE TYPE	0=volts, 1=amperes
490	245	PROCESS RANGE	0=TCJ, 1=TCK, 2=TCT, 3=TCR, 4=TCS, 5=TCE
491		LOAD CELL RANGE	0=1V/1mA, 1=10V/20mA
492	246	TEMPERATURE SCALE	3=15mV, 2=30mV, 1=60mV, 0=300mV
493		TEMPERATURE RESOLUTION	0=°C, 1=°F
494	247	TEMPERATURE OFFSET	0=0.1°, 1=1°
495			sign
496	248		digit 1
497			digit 0
		DISPLAY DECIMAL POINT	0=88888, 1=8888.8, 2=888.88, 3=88.888, 4=8.8888

498	249	FILTER P	0 to 9
499		FILTER E	0 to 9
500	250	READINGS AVERAGE	digit 2
501			digit 1
502	251		digit 0
503		BRIGHT	0=HI, 1=LO
504	252	LEFT ZEROS	0=no, 1=yes
505		RATE	0=16/s, 1=4/s, 2=1/s
506	253	ROUND	0=001, 1=002, 2=005, 3=010, 4=020, 5=050, 6=100
507		PRINT DATE AND TIME	0=off, 1=on
508	254	INTEGRATOR	0=no, 1=yes
509		TIME BASE	0=second, 1=minute, 2=hour, 3=day
510	255	INTEGRATOR FACTOR	digit 3
511			digit 2
512	256		digit 1
513			digit 0
514	257	FACTOR DECIMAL POINT	0=88888, 1=8888.8, 2=888.88, 3=88.888
515		TOTALIZER DECIMAL POINT	0=88888888, 1=8888888.8, 2=888888.88, 3=88888.888, 4=8888.8888, 5=888.88888, 6=88.888888, 7=8.8888888
516	258	LO-CUT	sign
517			digit 4
518	259		digit 3
519			digit 2
520	260		digit 1
521			digit 0
522	261	SECURITY CODE	digit 3
523			digit 2
524	262		digit 1
525			digit 0
526	263	SOFT LOCK 1	bit 0 =setpoint 1 bit 1 =setpoint 2 bit 2 =setpoint 3 bit 3 =setpoint 4

527		SOFT LOCK 2	bit 0 = input bit 1 = scaling+integrator+volume bit 2 = filters+display+round bit 3 = -
528	264	SOFT LOCK 3	bit 0 = analog output bit 1 = serial communication output bit 2 = logic inputs bit 3 = direct programming of setpoint values
529		SOFT LOCK 4	bit 0 = tare key function bit 1 = - bit 2 = - bit 3 = total lock
530	265	LOGIC FUNCTION CN2.1	0 to 36
531		LOGIC FUNCTION CN2.2	0 to 36
532	266	LOGIC FUNCTION CN2.3	0 to 36
533		LOGIC FUNCTION CN2.4	0 to 36
534	267	-	-
535		-	-
536	268	PROTOCOL	1=ASCII, 2=iso1745, 3=modbus
537		BAUD RATE	1=1200, 2=2400, 3=4800, 4=9600, 5=19200
538	269	ADDRESS TENS	0 to 9
539		ADDRESS UNITS	0 to 9
540	270	TRANSMISSION TO BETA-M	0=no, 1=yes
541		DELAY RS485	1=30ms, 2=60ms, 3=100ms, 4=300ms, 5=no delay

DINAMIC VARIABLES (READ ONLY)

MODBUS	Variable	Description	Format
276	Peak Value	Internal peak value	Long
278	Valley value	Internal valley value	Long
280	Tare value	Internal tare value	Long
282	Batch counter	Internal batch counter	Integer (1 word)
285	Totalizer	Internal totalizer counter	Float
287	Net value	Net value on display (with filters, round and hold)	Long
289	Gross value	Gross value on display (with filters, round and hold)	Long
291	Input signal value	Input signal value on display (with filters and hold)	Float
293	Setpoint1	Setpoint 1 value	Long
295	Setpoint2	Setpoint 2 value	Long
297	Setpoint3	Setpoint 3 value	Long
299	Setpoint4	Setpoint 4 value	Long
301	Batch	Batch Value on display (with filters and hold)	Integer (1 word)
302	Total	Total Value on display (with filters and hold)	Float
304	Peak	Peak Value on display (with filters and hold)	Long
306	Valley	Valley Value on display (with filters and hold)	Long
308	Net	Internal net value, without filter nor round	Long
310	Gross	Internal gross value, without filter nor round	Long
312	Input	Input signal value, no filter	Long
314	Net round	Net value with filters and round	Long
316	Gross round	Gross value with filters and round	Long
318	State of the setpoints and the logic inputs (0=deactivated, 1=activated)	bit 0 = setpoint 1 status bit 1 = setpoint 2 status bit 2 = setpoint 3 status bit 3 = setpoint 4 status bit 4 = logic input 1 status bit 5 = logic input 2 status bit 6 = logic input 4 status bit 7 = logic input 5 status	Byte



MODBUS	Variable	Description	Format
318	Options installed (0=not installed, 1=installed)	bit 0 = 2RE bit 1 = 4RE bit 2 = RS2 bit 3 = RS4 bit 4 = - bit 5 = BCD bit 6 = ANA bit 7 = -	Byte
319	Digits of the main display	digit 0 (LSB)	Byte
		digit 1	Byte
320		digit 2	Byte
		digit 3	Byte
321		digit 4	Byte
		digit 5 (MSB)	Byte
322		LED's -	Byte Byte
323	Digits of the auxiliary display	digit 0 (LSB)	Byte
		digit 1	Byte
324		digit 2	Byte
		digit 3	Byte
325		digit 4	Byte
		digit 5	Byte
326		digit 6 digit 7 (MSB)	Byte Byte
327	Version	units	Byte
		tens	Byte
328		hundreds	Byte
		'M'	Byte
329	'B'	Byte	
	Sensor Break	0=OK, 1=Broken	Byte
330	Display overflow (internal)	0=no, 1=yes	Byte
	Input overflow	0=no, 1=yes	Byte
331	Display overflow	0=no, 1=yes	Byte
	Totalizer overflow	0=no, 1=yes	Byte

TARE MODE



tArE1

On tArE1 mode at one press of the  key, the instrument stores the value shown on display at this moment, if it is not on overflow, the TARE LED lights and from this moment the shown value is **net** value (the measured minus the stored). If the instrument already has a TARE and press once again the TARE key the value shown at this moment will be added to the previous TARE value, being the sum of both the resulting TARE. To clear TARE value, see page 59.

tArE2

In this mode, the TARE key has no effect when the instrument is in RUN. The TARE value will be programmed manually, nevertheless the way of working will be the same that in tArE1. The edit menu is accessed from the RUN mode, with pressing the ENTER key which will take us a –Pro- and pressing the TARE key more than 3 seconds will enable us with the keys  and  to enter the tare value in memory and pressing the ENTER key goes back to –run- and TARE LED will be on, not allowing more TAREs from the keyboard, having to reschedule to override it.

tArE3

In this mode we have to program the “**net**” value, from RUN mode press more than 3 seconds the  and according the diagram on page 98, program the net value (usually indicated on the container). Action TARE, as in the tArE2 case will not take effect until a press of  key, being the instrument in RUN mode, also the TARE LED will light. The value stored now on TARE is the difference between the measured value at the moment of TARE was made and the “**net**” value programmed. Being the display shown, the difference between the measured and calculated tare. You will need to enter the programming menu and go through “CndSP” > “ModtA” to delete the TARE, the  key is inactive until reprogrammed.

Example:

A process using the liquid in a container that is known as the manufacturer's gross weight 100 Kg and 75 Kg net. It is used in the process of weighing a load cell connected to an instrument and need to know the net weight of liquid at every moment of the process. Selecting this mode of tare, net value would be introduced by editing. When the instrument is measuring the weight of the drum, now completely filled with liquid, which would be 100 kg, tare the instrument and the measure now shows 75 kg, and measuring from this value to 0 during the emptying of it.

Programming:

If have selected input Process or Potentiometer, on the menu 20 "CndSP" after submenu 27 "-Vol-" and with another push of  key you get the submenu **ModTA**.

If have selected input "Load Cell" on the menu 20 "CndSP" after the submenu 26 and pushing  key you get the submenu **ModTA**.







If selected Process or Potentiometer



If selected Load Cell



PROGRAMMING NET VALUE IN TARE MODE 3

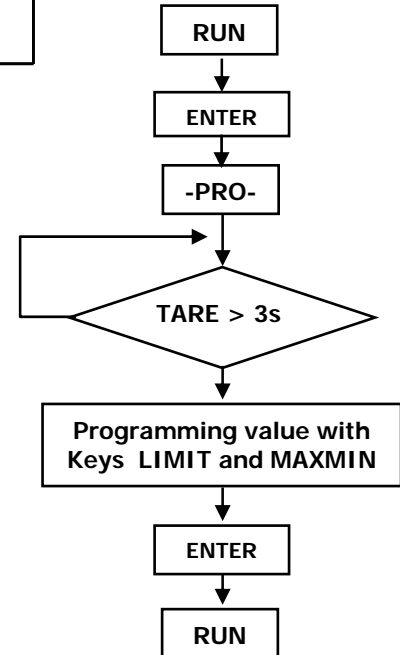

To edit the net value, being the instrument in RUN mode, press the  key to get the indication -Pro- then press the  key more than 3 seconds, showing the display the last TARE value programmed and the most left red digit blinking, with  key and  key program the **NET** value, usually indicated on the container, validate with  key and the instrument goes back to normal working, **at this moment and with the container over the platform should be pressed  key**, passing the instrument to show the programmed net weight and activating the TARE led, from this moment on the TARE key has no effect on the weight indication.



SENSOR BREAK

This function allows detecting any broken wire that connect the sensor "Load Cell" to the instrument. The analysis to detect the broken wires is done every 1,5 seconds and the response of Relays and ANA options (if used) will be the same if it were a overflow (**oVFLo**) situation, input signal greater than allowed.

NOTE: This detection system works only if the sensor is supplied with the excitation voltage from the instrument.

If the input "Load Cell" has been programmed, on the menu 20 "CndSP" after the submenu 28 with an other press of  key we got the submenu 29 **-Sbr- Sensor Break** and pressing  key is possible to select **-on-** to activate or **-off-** to deactivate.

If selected Load Cell



FAIL SAFE

Function that allows detecting the power supply fault or an instrument fault and in this way can be informed the PLC or another general system of supervision using the relay option programmed in this way.

This function can be programmed on any of the activated relay, in the submenu 31, 32, 33, 34 after the programming parameter “-Hi-Lo-” will show “-no nc-” (no=normally open), (nc=normally closed)

-nc- is the FAIL SAFE mode

SETPOINT VALUE

888888

HI-LO

HI

Lo

NO-NC when selected NC works in **FAIL SAFE** mode

no

nc

DLY-HISTERESIS

dLY

HYS1

HYS2

LATCH

no

YES

BLINK

no

YES

r.o.C. Function (rate of Change)

The function **r.o.C** is useful to detect the changing speed of display value, depending on programmed setpoint polarity we detect the increasing or decreasing.

In mode **r.o.C.**, if the setpoint values is, for example = 1000, that means that the alarm will be activated when the display value increase more than 1000 points per second.

If the setpoint value were, for example = -1000, the alarm would be activated when the display value decrease with a speed greater than 1000 points per second.

The **r.o.C.** alarms have the same programmable options than the rest of alarms, namely, you can choose the mode of action, HI-LO, NO-NC, Latch, delay-histeresys, LED-LED+blink. The only difference is if delay is selected, on the **r.o.C.** alarms not apply to the activation and deactivation, but only to the deactivation of the alarm. This function is applicable separately to activate each of setpoints.

Programming:

If has been programmed input: Process, Potentiometer, Load Cell in the submenu 31 CoMP after the “-VAL-” pressing the  key gets the function **r.o.C.**, or in the submenu 32 gets after the MaxF or totAL (if activated).

If has been programmed input : Temp, in the submenus 31, 32, 33, 34 gets after the -VAL-

Note: The **ovflo** situation (be by sensor break, or excess of input signal, or incorrect programming) leads to the relays to the rest situation that corresponds according to the program established.

PROCESS, POTENTIOMETER and LOAD CELL



(*) Only Setpoint 2

(**) Only if the totalized or integrator variable exist

THERMOCOUPLE and Pt100



doSE

If has been programmed input "Load Cell, Potentiometer or Process", **only in the submenu 31** is possible to select the function "doSE"

WAY of WORKING of SETPOINT1 in MODE "doSE"

When the function "doSE" is selected on the setpoint 1 menu, can not choose the comparison value, since it will be on the net value of the display. Nor can choose HI or LO mode as this will depend on whether the setpoint is positive (HI) or negative (LO) and the numerical value of setpoint will have to be mandatory to program on the direct programming of setpoint values routine (keys ENTER and LIMIT).

When exit from menu 31 with "doSE" option selected, the setpoint is locked and it doesn't work.

To start working have to enter on direct programming routine and gives it a value.

When you press ENTER, the set value is added to the net internal value of display (if positive, "and is automatically HI-mode) or subtracted (if negative," and is put in LO-mode).

At this time, enables the operation of the setpoint 1.

Each time the display increases (HI) or decrease (LO) in a number of points equal to the programmed setpoint 1 value will activate the output relay.

Likewise, if the logical function n° 30 has been programmed, the setpoint value will be added to the totalizer and increase the batch number in one unit.

If you also enable pin which is scheduled this logic function, two parameters are displayed in the main and secondary displays.

Activation of the relay output last time has been programmed on parameter "dLY" Setpoint1 menu or, if selected mode "LATCH", will be permanently activated until a reset is made of setpoints LATCH (logical function No. 25).

(*) It's not possible to program "trAC" if on the menu 31 has been programmed "doSE"

MENU 31

oFF	on	CoM	doSE
-----	----	-----	------

MENU 32

oFF	on	CoM	trAC(*)
-----	----	-----	---------

MENU 34

oFF	on	CoM	trAC
-----	----	-----	------

oFF	on	CoM	trAC(*)
-----	----	-----	---------

MENU 34

oFF	on	CoM	trAC
-----	----	-----	------

