

OPERATION MANUAL

Torque sensor Model 8655

© 2023

burster
präzisionsmesstechnik gmbh & co kg
All rights reserved

Manufacturer:

burster
präzisionsmesstechnik gmbh & co kg
Talstrasse 1 - 5 Postfach 1432
76593 Gernsbach 76593 Gernsbach
Germany Germany

Valid from: June 14, 2023

Tel.: +49 7224 645-0
Fax: +49 7224 645-88
Email: info@burster.de
www.burster.com

4403-BA8655EN-5699-061529

Warranty disclaimer

All information in the present documentation was prepared and compiled with great care and reproduced in accordance with effective control measures. This documentation may contain errors, and the information it contains and the corresponding technical data are subject to change without notice. Reproduction of any part of this documentation or its processing or revision using electronic systems is prohibited without the manufacturer's prior written approval.

Components, devices and measurement sensors made by burster präzisionsmesstechnik (hereinafter referred to as the "product") are the result of targeted development and meticulous research. From the date of delivery, burster provides a warranty for the proper condition and functioning of these products covering material and production defects for the period specified in the warranty document accompanying the product. However, burster waives any guarantee or warranty obligations or any additional liability for consequential damages caused by improper use of the product, in particular the implied guarantee of success in the market as well as the suitability of the product for a particular purpose. Furthermore, burster assumes no liability for direct, indirect or incidental damages or for consequential or other damages arising from the provision and use of the present documentation.

Trademark information

Intel Pentium® is a registered trademark of Intel Corporation. Windows®, Excel® are registered trademarks or trademarks of Microsoft Corporation in the United States and/or other countries. All brand or product names mentioned in this document are trademarks or registered trademarks of their respective trademark owners. By mentioning these trademarks, burster präzisionsmesstechnik gmbh & co kg is not laying claim to trademarks other than its own.



THE MEASUREMENT SOLUTION.

EU-Konformitätserklärung (nach EN ISO/IEC 17050-1:2010) EU-Declaration of conformity (in accordance with EN ISO/IEC 17050-1:2010)

Name des Ausstellers: burster präzisionsmesstechnik gmbh & co kg
Issuer's name:

Anschrift des Ausstellers: Talstr. 1-5
Issuer's address: 76593 Gernsbach, Germany

Gegenstand der Erklärung: Drehmomentsensor
Object of the declaration: Torque Sensor

Modellnummer(n) (Typ): 8655 / 8656
Model number / type:

Diese Erklärung beinhaltet obengenannte Produkte mit allen Optionen
This declaration covers all options of the above product(s)

Das oben beschriebene Produkt ist konform mit den Anforderungen der folgenden Dokumente:
The object of the declaration described above is in conformity with the requirements of the following documents:

Dokument-Nr. <i>Documents No.</i>	Titel <i>Title</i>	Ausgabe <i>Edition</i>
2011/65/EU + delegD (EU) 2015/863	Richtlinie zur Beschränkung der Verwendung bestimmter gefährlicher Stoffe in Elektro- und Elektronikgeräten <i>Directive on the restriction of the use of certain hazardous substances in electrical and electronic equipment</i>	2011 + 2015
2014/35/EU	Richtlinie zur Harmonisierung der Rechtsvorschriften der Mitgliedsstaaten über die Bereitstellung elektrischer Betriebsmittel zur Verwendung innerhalb bestimmter Spannungsgrenzen auf dem Markt <i>Directive on the harmonization of the laws of the Member States relating to the making available on the market of electrical equipment designed for use within certain voltage limits</i>	2014
2014/30/EU	Richtlinie zur Harmonisierung der Rechtsvorschriften der Mitgliedsstaaten über die Elektromagnetische Verträglichkeit <i>Directive on the harmonization of the laws of the Member States relating to electromagnetic compatibility</i>	2014
EN 61326-1	Elektrische Mess-, Steuer-, Regel- und Laborgeräte – EMV-Anforderungen – Teil 1: Allgemeine Anforderungen <i>Electrical equipment for measurement, control and laboratory use – EMC requirements – Part 1: General requirements</i>	2013
EN 61326-2-3	Elektrische Mess-, Steuer-, Regel- und Laborgeräte – EMV-Anforderungen – Teil 2-3: Besondere Anforderungen <i>Electrical equipment for measurement, control and laboratory use – EMC requirements – Part 2-3: Particular requirements</i>	2013

Gernsbach 18.11.2020 ppa. Christian Karius
Ort / place Datum / date Quality Manager

Dieses Dokument ist entsprechend EN ISO/IEC 17050-1:2010 Abs. 6.1g ohne Unterschrift gültig /
According EN ISO/IEC 17050 this document is valid without a signature

burster präzisionsmesstechnik gmbh & co kg

Talstr. 1-5 · DE-76593 Gernsbach
Tel. (+49) 07224-6450
info@burster.com

Geschäftsführer/Managing Director: Matthias Burster
Handelsregister/Trade Register: Gernsbach
Registergericht/Register Court: Mannheim HRA 530170

Kompl./Gen. Partn.: burster präzisionsmesstechnik Verwaltungs-GmbH
Handelsregister/Trade Register: Gernsbach
Registergericht/Register Court: Mannheim HRB 530130

burster is ISO 9001:2015 certified

www.burster.com

Contents

1. For your safety	6
1.1. Symbols used in the operation manual	6
1.1.1. Signal words.....	6
1.1.2. Pictograms	6
1.2. General safety instructions	7
2. Introduction	8
2.1. Intended use	8
2.2. Customer service	8
2.2.1. Customer service department.....	8
2.2.2. Contact person.....	8
2.3. Ambient conditions	9
2.3.1. Storage.....	9
2.3.2. Cleaning	9
2.4. Personnel.....	9
2.5. Contents of pack.....	10
2.6. Unpacking	10
2.7. Warranty	10
2.8. Modifications and maintenance	11
2.9. Definitions	12
3. Device design and general information	14
3.1. Mechanical design	14
3.2. Principle of operation	15
3.3. Static and quasi-static torques.....	15
3.4. Dynamic torques	15
3.4.1. Estimating the mechanical resonant frequency	16
3.5. Interference.....	16
4. Installation	17
4.1. Preparing for installation	17
4.2. Mechanical installation.....	17
4.2.1. Installation with mounting block	17
5. 8655 torque sensor with analog connection	18
5.1. Electrical connection.....	18
5.1.1. Power supply.....	18
5.1.2. Connector pin-out (standard sensor)	18
5.1.3. The connections in detail	19
5.1.4. Running cables	21
5.1.5. Extension cables	21
5.2. Measurement operation	22
5.2.1. Switching on.....	22
5.2.2. Speed limits.....	22
5.2.3. Check function	22

Torque Sensor 8655

6. USB version of the 8655 torque sensor	22
7. Options	23
7.1. Angle/speed measurement.....	23
7.1.1. General	23
7.1.2. Details	23
8. Calibration and adjustment.....	24
8.1. Factory calibration	24
8.2. Calibration certificate with accreditation symbol.....	24
8.3. Recalibration.....	24
9. Taking out of use.....	25
10. Technical data	26
10.1. Electromagnetic compatibility	26
11. Accessories available	26
12. Disposal.....	27



1. For your safety

The following symbols on the model 8655 torque sensor and in this operation manual warn of hazards.

1.1. Symbols used in the operation manual

1.1.1. Signal words



The following signal words are used in the operation manual according to the specified hazard classification.

	DANGER
High degree of risk: indicates a hazardous situation which, if not avoided, will result in death or serious injury.	
	WARNING
Moderate degree of risk: indicates a hazardous situation which, if not avoided, may result in death or serious injury.	
	CAUTION
Low degree of risk: indicates a hazardous situation which, if not avoided, could result in minor or moderate injury.	
NOTICE	
Property damage to the equipment or the surroundings will result if the hazard is not avoided.	

Note: It is important to heed these safety notices in order to ensure you handle the model 8655 torque sensor correctly.

IMPORTANT: Follow the information given in the operating manual.

1.1.2. Pictograms

	Electric shock hazard.
	Observe the advice for protecting the model 8655 torque sensor.

1.2. General safety instructions

The model 8655 torque sensor is state of the art, and is safe to operate. However, if the 8655 torque sensor is not used or operated as intended, it may present a hazard.

	 DANGER
	<p>Electric shock hazard! The following instructions must be followed to prevent electric shock and injuries:</p> <ul style="list-style-type: none">• In order to achieve high measuring sensitivity, the model 8655 torque sensor was not designed with the usual safety factors (2 ... 20) for machine designs. For applicable overload factors, see the data sheet.• Observe accident prevention regulations, including for accessories used.• Use the model 8655 torque sensor only in non-safety-critical applications.• Only use the model 8655 torque sensor outside of potentially explosive areas (Ex protected areas).

NOTICE

The following points must be observed to prevent injuries and damage to property:

- The limits for permissible mechanical, thermal and electrical loads are shown in the data sheet. These limits must not be exceeded. Take these limits into account when planning the measuring arrangement, and during installation (preferably with the display for the torque connected) and operation.
- Impacts and shocks may damage the model 8655 torque sensor (e.g. if it is dropped). Exercise due care when handling and fitting the 8655 torque sensor.
- Torque peaks in excess of the permissible overload may destroy the torsion shaft. Make sure that such peaks do not occur, or ensure that they are absorbed.
- Do not use the sensor together with impulse or impact drivers.

2. Introduction

IMPORTANT: Read the operation manual carefully before using the equipment, and keep it for future reference.

2.1. Intended use

The model 8655 torque sensor measures static and dynamic torques on rotating or stationary machine parts in either direction of rotation. You have the option of measuring rotational speed or angular displacement. The respective upper range value is shown on the type plate. For the dual-range sensor, the larger full-scale value is given. The USB version of the 8655 torque sensor transmits all measurement signals via USB.

Both the low mass of the model 8655 torque sensor and its high torsional rigidity are an advantage when measuring dynamic torques. However, you need to pay attention to the spring constant and the cut-off frequency of the model 8655 torque sensor with such measurements. You can find both of these in the data sheet. For more information on estimating the resonant frequency and measuring dynamic torques, see section 3.4 Dynamic torques on page 15.

The model 8655 torque sensor is maintenance-free thanks to its contactless transmission of the measurement signal. The electrical measurement signals can be transmitted to a remote higher-level electronic system, where they can be displayed, recorded, processed and used for control and regulation tasks.

Use the model 8655 torque sensor only for measuring torque and rotational speed or angular displacement.

Do not use the 8655 torque sensor in safety-critical applications.

The model 8655 torque sensor is **not intended for use as a safety device**.

2.2. Customer service

2.2.1. Customer service department

For repair inquiries, please call our customer service department on +49 7224 645-53.

Please have the serial number to hand. The serial number is the only way to clearly identify the technical version of the instrument so that we can provide help quickly. You will find the serial number on the type plate of the model 8655 torque sensor.

2.2.2. Contact person

If you have any questions relating to the model 8655 torque sensor, please contact your representative or go directly to burster präzisionsmesstechnik gmbh & co. kg.

Head office

burster präzisionsmesstechnik gmbh & co kg
Talstrasse 1 - 5
76593 Gernsbach
Germany

Phone: +49 7224 645-0
Fax: +49 7224 64588
Email: info@burster.de

Torque Sensor 8655

2.3. Ambient conditions

- Avoid radiant heat or cooling from one side.
- Protect the 8655 torque sensor from moisture.
- The 8655 torque sensor is **not** resistant to chemical agents. **Do not** use the sensor in a corrosive environment.
- Keep the bearings and connectors free of dust, dirt and other foreign matter.

2.3.1. Storage

Use clean packaging to package the model 8655 torque sensor. The 8655 torque sensor must be stored under the following conditions:

- Dry atmosphere
- No condensation
- Temperature between 0 °C and 60 °C.

2.3.2. Cleaning

	<div style="background-color: red; color: white; padding: 5px; text-align: center;">  DANGER </div> <p>Electric shock hazard! Disconnect the 8655 torque sensor from the electrical supply before cleaning.</p>
--	---

Disconnect the 8655 torque sensor from the power supply and use a dry cloth to clean the sensor.

	<div style="background-color: #004a87; color: white; padding: 5px; text-align: center;"> NOTICE </div> <p>Do not immerse the 8655 torque sensor in water or hold it under running water. Do not use strong cleaning agents as these may damage the 8655 torque sensor. Use a dry cloth to clean the device.</p>
---	---



2.4. Personnel

Personnel must be familiar with the relevant regulations. They must follow these regulations. Only trained personnel who are familiar with the applicable safety regulations are permitted to operate the model 8655 torque sensor.

2.5. Contents of pack

- Torque sensor model 8655
- Mating connector
- Digital operation manual on our website (www.burster.com)
- Digital data sheet on our website (www.burster.com)
- Optional: USB cable

2.6. Unpacking

	 DANGER
	<p>Electric shock hazard! Never connect up the 8655 torque sensor if the sensor shows signs of damage incurred in transit. Only ever use the 8655 torque sensor under the conditions specified in this operating manual.</p>

Inspect the model 8655 torque sensor for damage. If you suspect that the unit has been damaged during shipping, notify the delivery company within 72 hours.

The packaging should be retained by a representative of the manufacturer and/or the delivery company.

The model 8655 torque sensor should be shipped only in its original packaging or in packaging capable of providing an equivalent degree of protection. The model 8655 torque sensor must be held securely (immovable) in its packaging.

2.7. Warranty

burster präzisionsmesstechnik gmbh & co kg provides a manufacturer's warranty for a period of 24 months after delivery.

Any repairs required during this time will be made without charge. This does not include damage arising from improper use.

Please note the following when sending the model 8655 torque sensor in for repair:

- If there is a problem with the model 8655 torque sensor, please attach a note to the body of the device summarizing the fault.
- Technical specifications subject to change at any time without notice.
We also state explicitly that we do not accept liability for consequential damage.
- The instrument must always be dispatched in suitable packaging.

2.8. Modifications and maintenance

Note: The warranty shall be deemed void **immediately** if you open or dismantle the model 8655 torque sensor during the warranty period.

The model 8655 torque sensor does not contain any parts that are intended to be serviced by the user. The transmission system in the model 8655 torque sensor is maintenance-free. Only the manufacturer's own qualified personnel are permitted to open the model 8655 torque sensor.

It is not permitted to make any changes to the model 8655 torque sensor without the written agreement of burster präzisionsmesstechnik gmbh & co kg. burster präzisionsmesstechnik gmbh & co kg does not accept liability for damages or injury if this condition is disregarded.

Our recommendations

- Check the bearings at least once a year to see that they still move freely.
- Replace the special low-friction bearings after a maximum of 20,000 hours of operation. In continuous operation at high speeds it may be necessary to replace the bearings sooner.
- Check cables and connectors annually.
- It is up to you as the user to determine the recalibration interval. We recommend that you check/recalibrate the 8655 torque sensor after 12 months. You can find further information in section 8 Calibration and adjustment on page 24.

2.9. Definitions

Test side

The torque being measured is applied to the shaft on the test side of the 8655 torque sensor.

This side normally has the smallest moment of inertia.

You will see these markings on the test side of the model 8655 torque sensor:

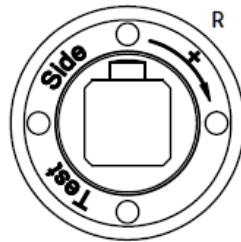

Figure 1: Test side, model 8655 torque sensor

Drive side

The drive side is the opposite side to the test side. The model 8655 torque sensor is also mechanically connected on this side.

This side normally has the larger moment of inertia.

You will see these markings on the drive side of the model 8655 torque sensor:

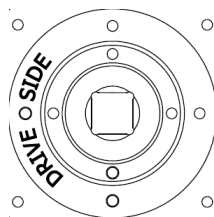

Figure 2: Drive side, model 8655 torque sensor

The torque direction

A torque is clockwise (clockwise torque) if the torque is exerted clockwise when **looking at the test side**. In this case you will get a positive electrical signal at the output from the 8655 torque sensor.

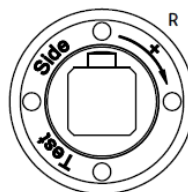

Figure 3: Clockwise torque (looking at the test side)

You can use model 8655 torque sensors to measure both clockwise and counterclockwise torques. If the torque is exerted in a counterclockwise direction (looking at the test side), you will get a negative signal at the output.

Torque Sensor 8655

Sign convention for torque measurement

If the shaft of the model 8655 torque sensor rotates clockwise (**looking at the drive side**), channel A leads channel B by 90°.

If the shaft of the model 8655 torque sensor rotates counterclockwise (**looking at the drive side**), channel B leads channel A by 90°.

Static and quasi-static torques

Static and quasi-static torques change their value only slowly or not at all. As long as they are below the rated torque, these torques can take any value.

Dynamic torques

A dynamic torque changes very rapidly and can even oscillate. In this case the frequency of the torque must remain well below the resonant frequency of the mechanical structure as a whole.

We recommend that you measure dynamic torques only if they do not exceed 70 % of the rated torque. The characteristics of your signal analysis and control systems must be taken into account during dynamic testing.

For more information on estimating the resonant frequency and measuring dynamic torques, see section 3.4 Dynamic torques on page 15.

3. Device design and general information

The figures given for the full dimensions, mass and power depend on the version of the 8655 torque sensor. Please refer to the data sheet for specific figures.

3.1. Mechanical design

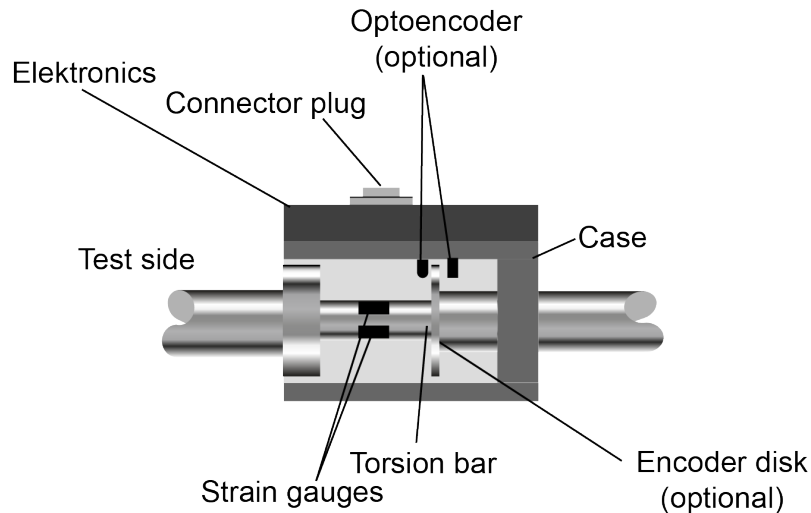

Figure 4: Basic design of the 8655 torque sensor

The 8655 torque sensor essentially consists of three elements:

- Measuring shaft
- Electronics box
- Housing

The measuring shaft is composed of torsion bar, strain gages, the rotor electronics, and power and signal transmission components. If the model 8655 torque sensor is fitted with the rotational speed or angular displacement measurement option, an incremental encoder disk is also fitted for measuring rotational speed or angular displacement (see section 7.1 Angle/speed measurement on page 23).

The electronics box contains the stator electronics. The housing holds the rotor and two ball bearings.

3.2. Principle of operation

Torque deforms the torsion shaft and, as it does so, also elastically and reversibly deforms the strain gages mounted on the shaft. The electrical resistance of these strain gages changes proportionally to their deformation.

The 8655 torque sensor has a total of four strain gages. These are arranged as a Wheatstone bridge circuit and are supplied with a DC voltage by the electronics. The output voltage from the strain gages changes in direct proportion to the measured torque. This voltage is amplified before being digitized by an analog/digital converter.

A 16-bit microprocessor processes these digital signals, encodes them and relays them to infrared LEDs, which send the signals to the stator as a serial light signal.

The stator receives this light signal and converts it back into electrical pulses before sending it to another microprocessor. This microprocessor controls a digital/analog converter which generates an analog voltage again (16-bit resolution). This analog voltage is the model 8655 torque sensor's measurement signal. It is proportional to the measured torque.

3.3. Static and quasi-static torques

Static and quasi-static torques change their value only slowly or not at all. As long as they are below the rated torque, these torques can take any value.

3.4. Dynamic torques

	NOTICE
	Resonance hazard Operating the 8655 torque sensor or the entire test setup close to its resonant frequency will result in permanent damage. Keep the torque frequency well below the resonant frequency of the mechanical test setup. Limit the peak-to-peak torque variation to 70 % of the rated torque.

Note: A calibration carried out for static torques is also valid for measuring dynamic torques.

3.4.1. Estimating the mechanical resonant frequency

The resonant frequency of the entire test setup depends on the spring constant “c” of the model 8655 torque sensor and the two moments of inertia “J1” and “J2”. These two moments of inertia include the respective connected rotating masses.

$$f_0 = \frac{1}{2 \cdot \pi} \cdot \sqrt{c \left(\frac{1}{J_1} + \frac{1}{J_2} \right)}$$

f₀: Resonant frequency in Hz

J₁: Moment of inertia 1 in kg · m²

J₂: Moment of inertia 2 in kg · m²

c: Spring constant in Nm / rad

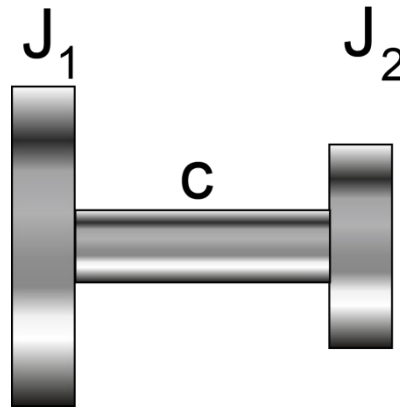

Figure 5: Resonant frequency model

Another method you can use to calculate resonant frequencies is the Holzer-Tolle method.

3.5. Interference

Possible sources of interference:

- Temperature change
- Temperature gradient
- Vibration
- Spurious forces
- EMC
- Electrical interference
- Magnetic interference
- Angular, axial or radial shaft misalignment (see also section 4.1 Preparing for installation on page 17).

IMPORTANT: Take suitable measures to counter these sources of interference because otherwise they may cause an incorrect measurement result.

4. Installation

4.1. Preparing for installation

Mounting surfaces

The mounting surfaces for the 8655 torque sensor or for the optional mounting block must be free of lubricants, particles or burrs.

4.2. Mechanical installation

4.2.1. Installation with mounting block

	NOTICE
	<p>Avoid excessive torques, bending moments or axial loads. Excessive torques, bending moments or axial loads may damage the 8655 torque sensor. Connect the electrical cable to the 8655 torque sensor during fitting and monitor the measurement signal. This signal must remain within the permitted range. Support the 8655 torque sensor during fitting to make sure it does not drop, and do not resort to hammering to aid installation.</p>

We recommend fitting the 8655 torque sensor with an associated mounting block, model number 8600-Z2X. Mounting blocks have the advantage of an extra locating pin to help align the 8655 torque sensor easily. If the 8655 torque sensor needs to be removed temporarily from the setup, the mounting block avoids any time-consuming realignment when it is refitted.

Couplings should be used for easy mounting and integration into your equipment; further information in data sheet 8690 (<https://bit.ly/3hDTzAn>).

Mounting instructions



This is how it works

1. Clean the square shaft and other contact and mounting surfaces on your components. At the time of fitting, there must be no foreign matter, burrs or lubricants on these components.
2. Fit the 8655 torque sensor on the mounting block. Use the locating pin to center the 8655 torque sensor on the mounting block then screw-fasten the sensor to the block.
3. First roughly align the mounting block. Initially only loosely tighten the mounting screws on the mounting block.
4. Connect the torque sensor to your equipment via the square shaft.
5. Now align the mounting block precisely. This avoids any unnecessarily high reaction forces, while also reducing the load on the coupling and any spurious forces acting on the 8655 torque sensor. It is usually sufficient, at low rotational speeds ($< 2000 \text{ min}^{-1}$), to align the coupling using a straight edge in two perpendicular planes. We do recommend, however, using a dial gage or laser to align the coupling and/or the shaft ends.
6. Once you have fitted all shafts into the coupling hubs and correctly aligned all parts, tighten the fixing bolts on the mounting block.

IMPORTANT: Make sure you do not move the mounting block when tightening.

5. 8655 torque sensor with analog connection

5.1. Electrical connection

5.1.1. Power supply

The operating voltage is supplied to the standard model of the 8655 torque sensor via the connecting plug.

5.1.2. Connector pin-out (standard sensor)

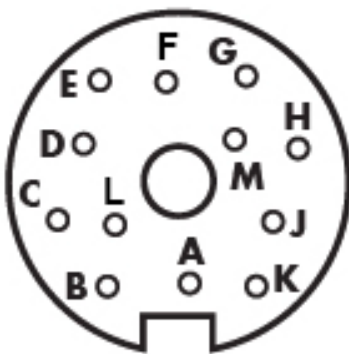

Pin:	Funktion Function:
C	Momentausgang Torque, voltage output
D	Momentausgang (Masse) Torque, output ground
F	Speisespannung Sensor supply, voltage
E	Speisespannung (Masse) Sensor supply, ground
K	Kalibriersignalansteuerung Control input
L	Nicht belegt not connected
B	Winkelausgang B Angular displacement Ch. B
J	Masse für Kal, $M_{\text{rot}} \angle$ GND für Kal, $M_{\text{rot}} \angle$
G	Winkelausgang A (Drehzahlausgang) Angular displacement CH. A (Rotary speed, output)
A, H, M	Nicht belegt not connected
Gehäuse case	Abschirmung Shield

Torque Sensor 8655

5.1.3. The connections in detail

Voltage output for torque

The voltage output for torque consists of an operational amplifier with a downstream low pass filter.

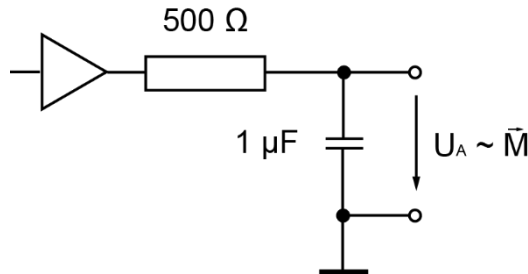

Figure 6: Voltage output for torque

The connected evaluation circuit should be high impedance ($> 10 \text{ M}\Omega$). The reference is the potential-separated torque output ground. You can connect this to the supply ground on the evaluation device.

TTL output for rotational speed / angular displacement

Both channels are designed the same way. A TTL signal is available directly, without additional external circuitry. The reference here is the supply ground. You can connect this to the torque output ground on the evaluation device.

Note: In conjunction with the internal pull-up resistor, the cable capacitances form a low-pass filter. You should therefore use the shortest possible, high-quality and low-capacitance cable for maximum transmission quality.

Here the external voltage is superimposed on the internal voltage source. As a result, for example, you can connect the model 8655 torque sensor directly to a PLC input with positive logic (not for American PLCs). Using the same connection method you can reduce problems with transmission quality with longer cables.

Guide values are $12 \text{ V} / 1 \text{ k}\Omega$ (0.5 W).

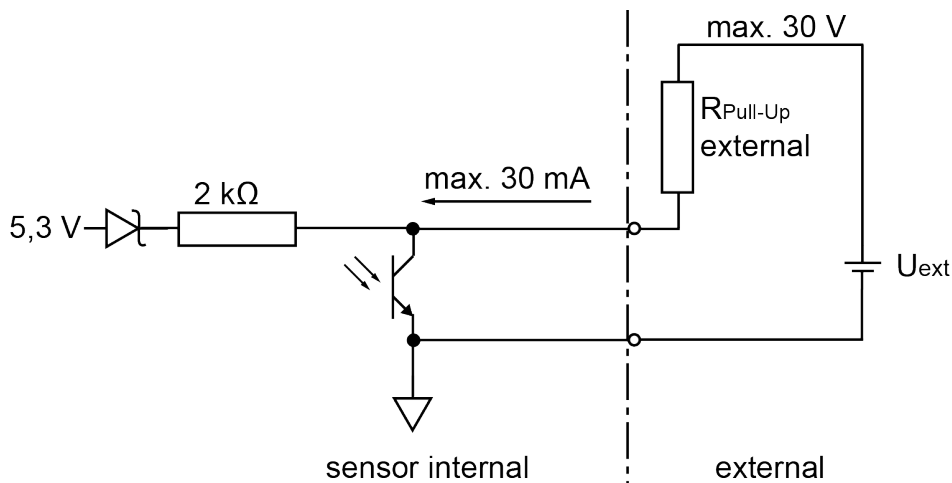

Figure 7: Open collector output

TTL output on 3.3 V or other logic

The diagram shows adaptation for 3.3 V logic. For other logic levels, appropriate Zener diodes need to be used.

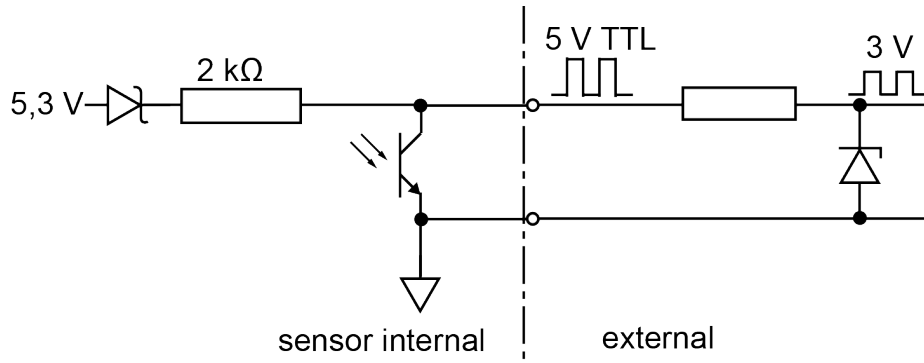

Figure 8: Resistance 10 kΩ, 3.3 V Zener diode

Longer transmission paths up to approx. 10 m

	<h3>NOTICE</h3>
<p>Danger of excessive heating. When connected to a voltage source, the 8655 torque sensor overheats. This overheating will permanently damage the 8655 torque sensor. Always use a pull-up resistor in the voltage source connection.</p>	

Depending on the cable type, cable cross-section, cable length and frequency, you may need to select a somewhat smaller pull-up resistor.

Pay attention to the maximum current and voltage values, and to the fact that considerable power is dissipated at the pull-up resistor and Zener diode.

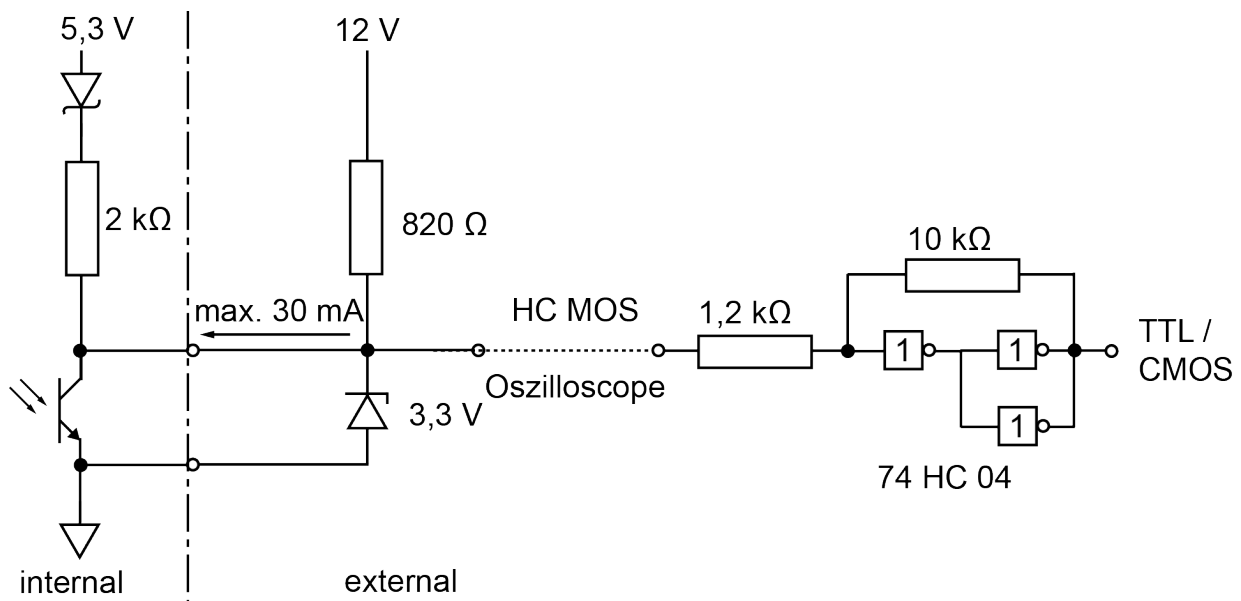

Figure 9: Longer transmission paths

5.1.4. Running cables

Electrical and magnetic fields can often be picked up by the test leads, causing interference. Such interference mainly stems from power cables running parallel to the test leads, but can also be caused by contactors, thyristor controllers, variable frequency drives and electric motors in the vicinity. Ensure these are a sufficient distance away and route test leads through a grounded steel pipe if necessary.

Galvanic interference can also occur, particularly if the measurement chain is grounded at multiple points creating differences in electrical potential. These ground loop currents can be avoided by either disconnecting the double grounding or bypassing it by running a particularly low-resistance ground cable (6-10 mm²) parallel to the test lead.

In general the following applies:

- The 8655 torque sensor must be grounded via its mounting screws.
- Run the cable loosely and with enough play in the cable to allow for any movement.
- Avoid any tension on the connecting plug.
- Avoid excessive lengths. If that is not possible, snake the cable. This will reduce the effective induction area.

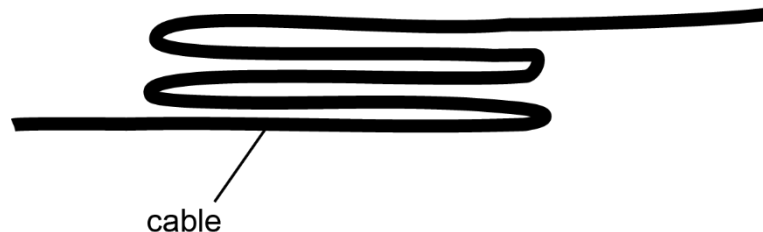

Figure 10: Running a cable with excess length

- Position the model 8655 torque sensor outside of the electromagnetic field of high-energy equipment. This includes transformers, motors, contactors, frequency converters and so forth. Otherwise the electromagnetic fields from such equipment will act with their full effect on the measuring chain, causing incorrect measurements.
- Route the measuring leads separately from power cables. If the measuring leads are laid parallel to such cables, the latter will cause inductive and capacitive interference.

Note: In some cases it is helpful to pull an extra shield as additional protection over the measuring cable, or to lay the cable in a metal tube or pipe, which should additionally be grounded if necessary.

5.1.5. Extension cables

- Always use shielded, low-capacitance cables.
- We recommend cables from burster präzisionsmesstechnik gmbh & co kg. These cables meet the relevant requirements.
- When extending cables, make sure connections are made correctly and with proper isolation.
- Make sure that the cable cross-section is sufficient.

Note: If you use extension cables it is not necessary to recalibrate the model 8655 torque sensor. However, you will need to adjust the entire measuring chain.

IMPORTANT: If a burster cable of type 99540-000F-05200XX is ordered with the sensor, a ceramic capacitor is supplied with the cable. This ceramic capacitor is needed only with torque sensors that include the angle/speed measurement option. The effect of the ceramic

capacitor is to suppress potential cross-talk from the angular displacement / rotational speed output to the torque output. Connect the ceramic capacitor between the torque output and torque GND.

5.2. Measurement operation

5.2.1. Switching on



This is how it works

1. Apply the operating voltage to the model 8655 torque sensor.
2. The model 8655 torque sensor goes through a self-test mode lasting 4 seconds after power-up. After the self-test has been completed, the sensor is ready for operation.

5.2.2. Speed limits

	NOTICE
<p>Excessive speeds will damage the model 8655 torque sensor. Excessive forces arise above the maximum speed. Always operate the 8655 torque sensor below the maximum speed (see data sheet).</p>	

5.2.3. Check function

When a voltage U_b is applied to the test input, the 8655 torque sensor outputs a signal of exactly 10.000 V at the analog output.

6. USB version of the 8655 torque sensor

For the USB version or when using the DigiVision PC software, you can configure the sensor and display and record the measured values via the user interface. You can use the DigiVision Light version free of charge and download it via the download area on our website www.burster.com. You can find more information about the DigiVision software and its use in the accompanying operation manual (<https://bit.ly/3Ls86wO>).

7. Options

7.1. Angle/speed measurement

7.1.1. General

The model 8655 torque sensor can be supplied with an integrated angular displacement / rotational speed measurement capability. For technical details on the evaluation of speed or angle of rotation signals, see section 7.1.2 Details on page 23.

An encoder disk with 400 increments is available for integrated angle of rotation / speed measurement; it provides a maximum angular resolution of 0.225°.

7.1.2. Details

For angle of rotation / speed measurement, an optoencoder scans a rotating encoder disk. This incremental encoder disk is made from a transparent material with opaque lines on it. This design is basically a high-resolution and fast light barrier. In operation, it generates a certain number of electrical pulses with each rotation. The frequency of these pulses is therefore dependent on the rotational speed of the shaft and the number of lines on the encoder disk.

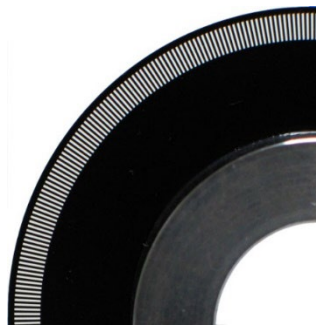

Figure 11: Close-up view of encoder disk

If the 8655 torque sensor includes the speed/angle option, the speed/angle output supplies a 5 V TTL signal. For the USB version of the 8655 torque sensor, the measurement data for the torque and also for speed and angle is transmitted digitally via USB.

The principle of measuring angular displacement is the same as for measuring rotational speed. However, in this case the model 8655 torque sensor reads two channels. Output channel A leads channel B by 90°, which also allows the shaft's direction of rotation to be identified.

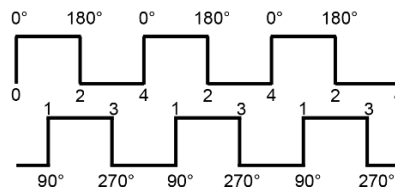

Figure 12: Angle of rotation measurement, channels offset by 90°

To detect the angle of rotation, you need to evaluate the rising and falling pulse edges for both channels (four-edge decoding). Hence the angular resolution is four times the number of lines on the encoder disk. An encoder disk with 400 lines therefore gives a resolution of $360 / (4 \times 400) = 0.225^\circ$.

For more information on the sign convention, see section 2.9 Definitions on page 12.

8. Calibration and adjustment

Model 8655 torque sensors from burster präzisionsmesstechnik gmbh & co kg are already traceably adjusted and tested in the factory. As an option, we offer factory calibration of the model 8655 torque sensor.

8.1. Factory calibration

As part of the traceable burster factory calibration, the 8655 torque sensor is checked for calibratability, and is then calibrated and marked with a calibration label, and a calibration certificate is issued.

The burster factory calibration certificate includes the following information as a minimum:

- Measurement values and measurement uncertainty
- Reference standards used including measurement uncertainty and traceability
- Zero offset, rated output and interpolation error
- Peak-to-peak range, hysteresis voltage and toggle (relative zero offset right-left)

8.2. Calibration certificate with accreditation symbol

Calibration of the model 8655 torque sensor is carried out by an ISO 17025 accredited calibration laboratory (DAkkS). Calibration is carried out according to DIN 51309 with 8 torque levels.

It is essentially the user's responsibility to determine appropriate periods for recalibration. In the case of an accredited calibration, the user should note that according to current standards (DIN 51309), the validity of the calibration lasts for no longer than 26 months.

8.3. Recalibration

Quality management standards require regular calibration of any measurement and test equipment that you use in quality-related processes. The reason for this is to ensure measurements are always made correctly, thereby keeping the risk of measurement errors in check.

We recommend that all measurement and test equipment is inspected every 12 months. We advise an immediate inspection if any damage is suspected.

Shorter intervals are recommended in the following cases:

- Overload of the 8655 torque sensor
- Following a repair or overhaul
- After improper use of the model 8655 torque sensor
- When required by quality standards
- Where there is a specific traceability requirement

If you have any questions about the 8655 torque sensor or calibration, please contact our Customer Service team by phone on +49 7224 645-53 or by email at service@burster.de.

9. Taking out of use

- Remove the 8655 torque sensor properly.
- Protect the 8655 torque sensor from knocks.
- Protect the 8655 torque sensor against bending moments.
- Support the model 8655 torque sensor.
- Do not drop the model 8655 torque sensor **under any circumstances**.

10. Technical data

Please refer to the enclosed data sheet for the technical specification. The latest version of the data sheet is available at <https://tinyurl.com/3cx6jz5s>.



Figure 13: Technical data QR code

10.1. Electromagnetic compatibility

Interference immunity

Interference immunity in compliance with EN 61326-2-3:2006

Industrial environment

Interference emission

Interference emission in compliance with EN 61326-2-3:2006

11. Accessories available

Please refer to the enclosed data sheet for details of the accessories available. The latest version of the data sheet is available at <https://tinyurl.com/3cx6jz5s>.



Figure 14: Accessories available

12. Disposal



Battery disposal

In Germany, the end user is legally obliged to return all used batteries, and it is illegal to dispose of batteries in the household waste. This law may also affect you as purchaser of the instrument described here. Please dispose of your used batteries properly and in accordance with national statutory regulations. Either take them to the relevant collection point in your organization or to the collection points provided by your local authority, our company or any battery retail outlet.

Instrument disposal

If your instrument is no longer usable, please comply with your legal obligations by disposing of the instrument described here in accordance with statutory regulations. You will then be helping to protect the environment!