

Workstation Systems



Assemblysystems



5 important reasons for choosing complete solutions by Elabo



1

We think things through to the end

The Elabo planning service is exactly what you need when designing professional, functional production flows. We analyse your working steps right up to the finished product and then generate a convincing, coherent realisation concept with short route times and high productivity. By the way; this service is provided to you free of charge.



2

Always at the cutting edge

Elabo systems are designed for evolution; they change to fit the requirements and tasks you set the system. Even if the requirements and intended purposes are completely redefined, TaMas (work stations) and TaMo (mobile systems) stand out due to their uncomplicated adaptability as conversion and extension-capable organisms for the modern world of work.

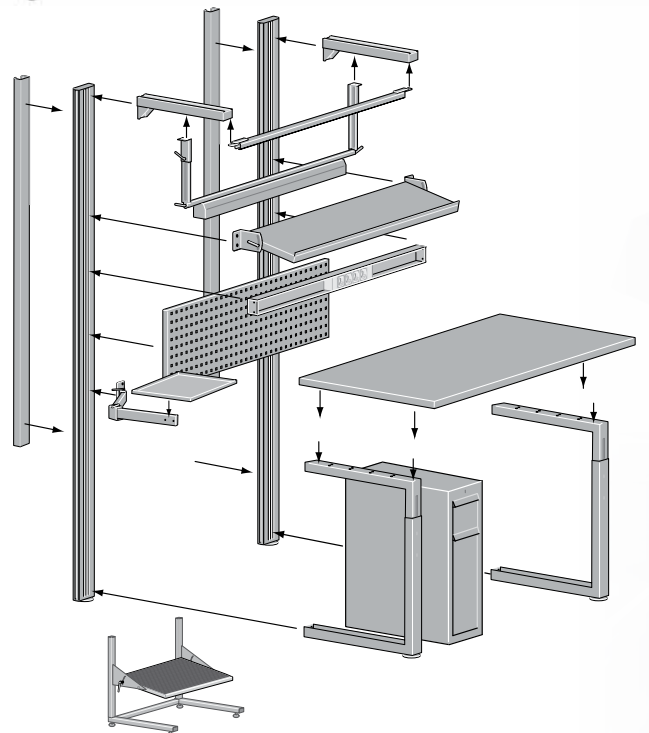

3

Optimum investment security

Elabo has represented "Quality in detail" since 1972. From profile columns through tabletops right up to high quality electrical devices or compressed air connections: Our 35 employees delegated for development tasks only make use of the best materials and the most robust solutions so that your application can be used for many years with success. In addition, almost unlimited extension possibilities ensure that you are able to change and supplement your system repeatedly for optimum handling of your tasks.



4

Optimised ergonomics

Relaxed posture at the work stations. This is not a luxury, but rather reality for people working at and with Elabo assembly systems on which the installations above the tabletop also "move", allowing handling spaces to be adapted perfectly to requirements. This increases concentration capabilities and promotes good health amongst employees. A win-win situation for the company and the employees.



5

Professional electronics and electrotechnology

Obtain integrated power supply systems, measuring and testing equipment and other electrical and electronic devices from specialists. Maximum reliability, safety mechanisms for protection of the user and durable quality, firmly fixed and safely stored, make the Elabo work station or also the Elabo production and assembly line a real plus for your department. Of course, we are happy to give you detailed advice so that you receive the best possible solution.



Individual work stations and linked production lines



■ We design and plan your production with you, coordinate the project, offer you as your central partner the procurement of almost all components from one source, organise the assembly and the installation of the devices and then hand over your new turnkey solution.



TaMo

■ Electrics and electronics with maximum power in the smallest space: Elabo have been realising this principle successfully in industrial companies in all sectors since 1972. The required components and devices are inserted as modules into a strip or aluminium channel and fixed. In this way your work station can be equipped in the most efficient possible way with all the electrical and electronic functions you might require, and this equipment can always be kept to hand.

■ Elabo provides two own product ranges for production and manufacturing. Both of these, TaMas and TaMo, have been generated from comprehensive user experience and are used internally at the Elabo concern. The conceptual design of both the "standing tables" (TaMas) and the mobile systems (TaMo) are modular systems which are able to integrate different components; also devices and accessories from other companies which have the right dimensions can easily be adapted.



TaMas Lift

also available with high-performance electromotive elevation adjustment.

Testing technology and conveyor systems

■ Elabo is the provider with whom you can avoid unknown interfaces and therefore cycle time losses. You will receive from us unequalled integrated testing technology which, through prior individual testing, makes complex dismantling and repair work superfluous. In addition, transport to a separate test station is no longer necessary.



■ We also design conveyor systems and different components such as roller conveyors, lifting stations, chain conveyors or vertical conveyors so that they do not represent "foreign objects", but can be integrated consistently into the overall design.



Project Management

The best advice from the start.

■ Whenever a planning challenge is pending: we are there to assist you. Due to our almost four decades of supervision and realisation of projects in this industry, we know what is important. We provide you with professional complete solutions from one source and do everything to optimise your production flow - which also relieves strain on your employees – in an expedient and well thought-out manner. We continue to provide you with assistance subsequent to your purchase and support you during running operations, for example with our device service.



References

ABM Greiffenberger Antriebstechnik GmbH

SIEMENS AG

SMA Regelsysteme GmbH

ELGEBÄ Gerätebau GmbH

SAMSON AG

PFALZWERKE

STENGEL Apparatebau GmbH

MASO Prozeß Pumpen GmbH

MBS GmbH

MAP GmbH

SIEMENS AG, A&D LD

FEUERWEHR Nürnberg

SUSPA Holding GmbH –

GB Automotive & Industrie

DEPRAG Schluz GmbH & Co.

E-T-A GmbH

TRENCH Germany GmbH

BOSCH Rexroth Elec. Drives & Control GmbH

ALSTOM Power Conversion GmbH

LIEBHERR Elektronik GmbH

TELEMOTIVE AG

TRILUX GmbH & Co. KG –

Lichttech. Spezialfabrik





Training | Measuring | Testing | Assembling | Controlling



ELABO GmbH –
a company of the
euromicron group
Roßfelder Straße 56
74564 Crailsheim
Deutschland
Fon +49 7951 307-0
Fax +49 7951 307-66
info@elabo.de
www.elabo.de