

# Series CCT

**Signal Converters with isolation  
for Voltage signals in AC and DC**



**CCT-01**  
**CCT-08**

**Voltages in DC**  
**Voltages in AC**

**up to 650 Vdc**  
**up to 650 Vac**

*IDEAL SOLUTION to convert a wide range of analogue signals (process, temperatures, current, frequencies...) to standard 10Vdc or 20mA process signals, for further retransmission to a remote data acquisition system or PLC's. The galvanic isolation offered by the CCT instruments between the signal circuit and the remote equipment, reduces to a minimum any eventual problem related to ground loops between different circuits.*

# Models CCT-01 and CCT-08

## Converters for AC and DC voltages

Signal converters for DC and AC single-phase voltages. Selection of input and output ranges with internal jumpers and potentiometers. Galvanic isolation between input, output and power circuits.



### Order Reference

CCT	Model	Power	Input	Output
	<b>01</b>	<b>0</b>	<b>0/100V</b>	<b>4/20mA</b>
	- 01	-0 (230 Vac)	0/650 Vdc	4/20mA
	- 08	-1 (115 Vac)	0/100V	0/10Vdc
		-2 (24 Vac)	0/10V	...
		-3 (48 Vac)	0/1V	
		-6 (24Vdc isolated)	0/100mV	
			...	

### Technical Data

Accuracy CCT-01	Class <0.2
Accuracy CCT-08	Class <0.3
Ripple	<0,5 %
Temperature coefficient	<0,015 %/ °C
Pass band	1.5 Hz (-3 dB a 3Hz)
Response time	<250 mSec.
Output in mA	0/20 mA / 4/20 mA, ... R <sub>L</sub> < 600 Ohms max. 22mA active output loop
Output in Vdc	0/10 Vdc, 0/1 Vdc, ... R <sub>L</sub> > 1000 Ohms max. 11Vdc
Isolation	2 KVe <sub>eff</sub> / 50Hz / 1 min (tested at 4 KVe <sub>eff</sub> )
Isolated circuits	input / output / power
Weight	270 gr.
Wire section	4mm <sup>2</sup> maximum
Housing IP protection	IP40
Terminals IP protection	IP20
Housing material	polycarbonate, light grey RAL 7032, UL 94 V-1
Mounting	standard DIN rail (DIN46277,
DIN EN 50022) (35 x 7,5mm) (1,38 x 0,3")	
Terminals	Polycarbonate, UL 94 V-2
Consumption	<1,5 VA
Storage temperature	-30 to +80 °C
Working temperature	-10 to +60 °C

### Access to internal circuits

With a flat screwdriver, force the front cover and walls towards **A** and **B**, until fixations '3' are free. Take the instrument from points '2', and extract it pulling towards **C**, until the internal circuits appear. The internal circuits have the following names:

- ME .- Signal Input Module
- MS .- Signal Output Module
- MA .- Power Module
- MP .- Personalized Module

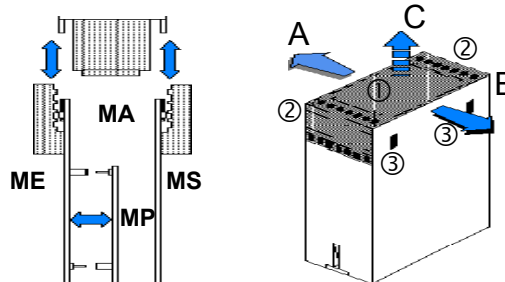

### Power options

The CCT converters allow different power modules in AC and DC. The instrument does not have internal protection fuse. Following is a recommendation on value and type of fuse for each power module available.

Ref.	Power	Fuse Recommended
«0»	230 Vac 50/60 Hz	50 mA Time Lag
«1»	115 Vac 50/60 Hz	100 mA Time Lag
«2»	24 Vac 50/60 Hz	300 mA Time Lag
«3»	48 Vac 50/60 Hz	150 mA Time Lag
«6»	24 Vdc	300 mA Fast Fuse

# CCT-01

## DC Voltage Signals up to 650 Vdc



Signal converter for DC voltage signals. Internal jumper selection for 5 different ranges of measure, ranging from 0/100 mVdc up to 0/650 Vdc.

### INPUT RANGE SELECTION

Configure the desired Vdc input range by selecting the appropriate jumpers on «MP» module, as shown on the table below:

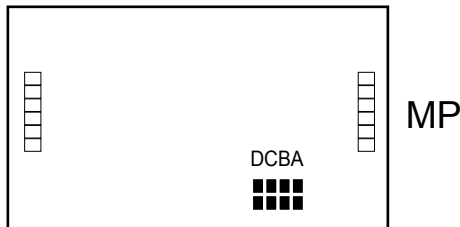

RANGE	JUMPERS «MP» / «ME»	OVERLOAD	Zin	MINIMUM RANGE
650 Vdc	B / ---	1000Vdc	1 MOhm	100V
100 Vdc	D / ---	1000Vdc	1 MOhm	10V
10 Vdc	--- / ---	1000Vdc	1 MOhm	1V
1 Vdc	--- / ---	75Vdc	100 KOhm	100mV
100mVdc	A / ---	25Vdc	100 KOhm	10mV

### CONNECTIONS

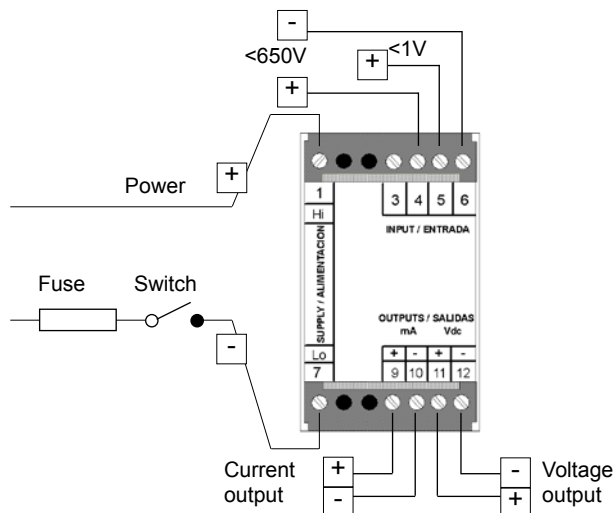

# CCT-08

## AC Voltage Signals up to 650 Vac



Signal converter for AC single-phase voltage signals. Internal jumper selection for 5 different ranges of measure, ranging from 0/100 mVac up to 0/650 Vac.

### INPUT RANGE SELECTION

Configure the desired Vac input range by selecting the appropriate jumpers on «MP» module, as shown on the table below:

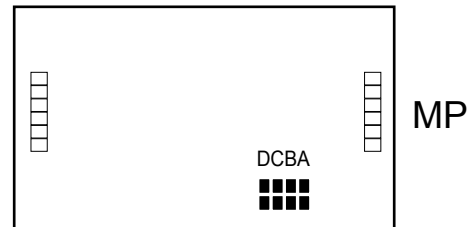

RANGE	JUMPERS «MP» / «ME»	OVERLOAD	Zin	MINIMUM RANGE
650 Vac	B / ---	750Vac	1 MOhm	100V
100 Vac	D / ---	750Vac	1 MOhm	10V
10 Vac	--- / ---	750Vac	1 MOhm	1V
1 Vac	--- / ---	75Vac	100 KOhm	100mV
100mVac	A / ---	25Vac	100 KOhm	10mV

### CONNECTIONS

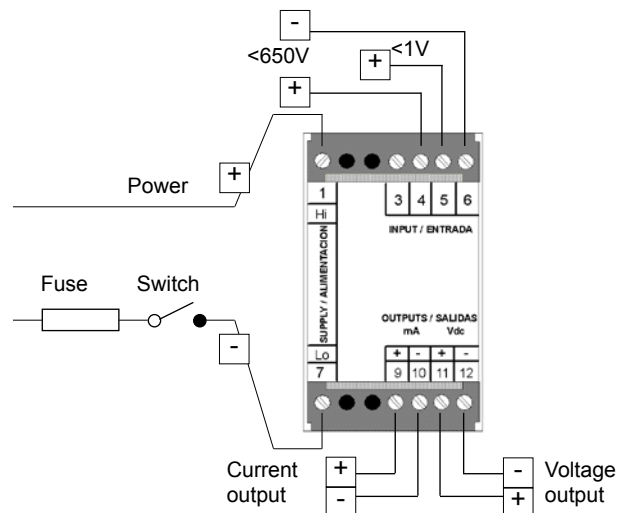

### Output signal module (MS)

The CCT has available outputs in voltage and current. Only one of the outputs can be active. Additional to the standard 0/10 Vdc and 4/20mA outputs, it is possible to reconfigure the instrument to any of the outputs shown in the table below.

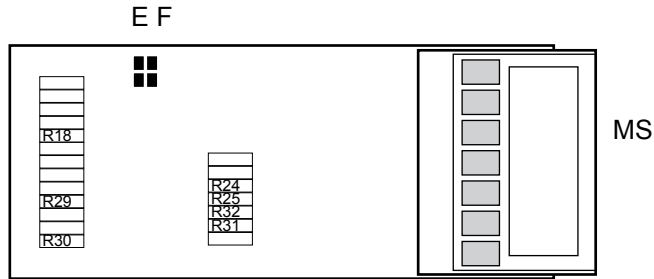

Other mA outputs (Resistances in Ohms)			Other Vdc outputs (Resistances in KOhms)					
OUTPUT	R18	R24	R25	OUTPUT	R29	R30	R31	R32
0/5mA	---	100	---	±10Vdc	49,9	---	200	---
0/10mA	---	49,9	---	0/1Vdc	---	---	11	100
1/5mA	100K	124	---	0/5Vdc	---	---	100	100
0/20mA	---	---	24,9	1/5Vdc	---	100	66,5	100

Jumpers E and F .- Closed in 4/20 mA output. Open for other outputs  
 Note .- The symbol «- - -» means «NOT installed»

### Readjustment procedure

- 1.- Open the housing to access the instrument internal circuits
- 2.- Select jumpers on boards «ME», «MP» and «MS»
- 3.- Connect signal generator to signal input terminals
- 4.- Connect multimeter to signal output terminals
- 5.- Power up the instrument as indicated on the label
- 6.- Generate the low signal level and operate potentiometer P1 on «ME» until the multimeter shows the desired signal output
- 7.- Generate the high signal level and operate potentiometer P2 on «ME» until the multimeter shows the desired signal output
- 8.- Repeat steps 6 to 7 in order to correct deviations and check the adjust

### Mechanical dimensions mm (inch)

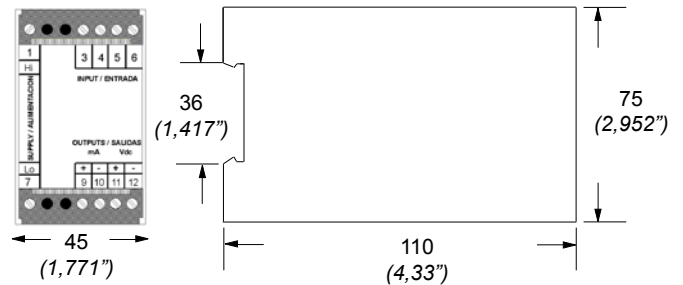

### Input signal module (ME)

Placed on the «ME» module are the potentiometers and jumpers for Zero and Gain adjustment.

- Jumper 1 .- Closed for Gross Positive Offset
- Jumper 2 .- Closed for Gross Negative Offset
- Jumper A .- Closed for Fine Negative Offset

- Jumper B .- Closed for Maximum GAIN
- Jumper C .- Closed for Middle GAIN
- Jumper B and C .- Open for Minimum GAIN

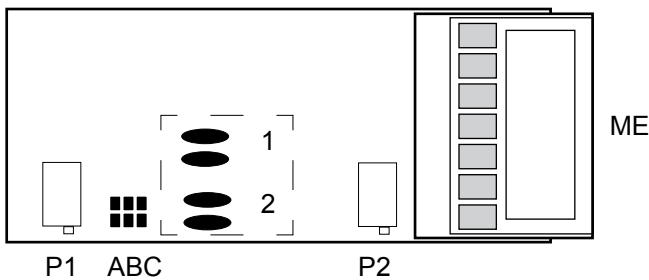

- P1 .- Zero Adjust Potentiometer
- P2 .- Gain Adjust Potentiometer

### CE Declaration of conformity

Manufacturer FEMA ELECTRÓNICA, S.A.  
 Altimira 14 - Pol. Ind. Santiga  
 E08210 - Barberà del Vallès  
 BARCELONA - SPAIN  
 www.fema.es - info@fema.es

Series CCT, models 01, 04, 06, 08, 20, 22, 23, 24, 25, 26, 27, 32, 55I, 55V, 80, 90, 95

The manufacturer declares that the instruments indicated comply with the directives and rules indicated below.

Directive of electromagnetic compatibility 2004/108/CEE  
 Directive of low voltage 73/23/CEE

Security rules 61010-1  
 Emmission rules 50081-1  
 Immunity rules 50082-1

Barberà del Vallès October 2009  
 Daniel Juncà - Quality Manager