

Tradinco Instrumenten-Apparaten BV
Industrieweg 74
P.O. Box 37
2650 AA Berkel en Rodenrijs
The Netherlands

Telephone +31 10 5112911
Telefax +31 10 5115114
E-mail info@tradinco.com
Internet www.tradinco.com

Tradinco 
Instruments®
The Calibration Company

8810 HIGH PRESSURE PRECISION REGULATOR

- **Exceptional low torque**
- **Excellent accuracy**
- **Standard inlet, outlet and monitoring port connections**
- **Small dimensions**
- **Panel mounting included**



Tradinco Model 8810 High Pressure Precision Regulators are designed to reduce gas inlet pressures safely up to 350 bar specifically for test applications. They accurately provide outlet pressure ranges up to 0-350 bar. This venting regulator allows the user to reduce pressures in a closed ("dead end") system by venting the down stream pressure through the regulator. The special design and materials used for the construction result in an exceptional low torque, enabling pressure settings with an excellent accuracy.

TECHNICAL SPECIFICATIONS

Media

All gasses compatible with the materials of construction

Max. rated inlet pressure

350 bar

| Ordering Code | Range |
|---------------|-------------|
| 8810 - 16 | 0 - 16 bar |
| 8810 - 25 | 0 - 25 bar |
| 8810 - 40 | 0 - 40 bar |
| 8810 - 60 | 0 - 60 bar |
| 8810 - 100 | 0 - 100 bar |
| 8810 - 160 | 0 - 160 bar |
| 8810 - 250 | 0 - 250 bar |
| 8810 - 350 | 0 - 350 bar |

Test pressure

150% of inlet rating

Mechanical design pressure

300% of inlet rating

Materials of construction

Body: brass chrome plated

Seats: kel-F

Sensor: brass/ss

Seals: buna-N

Operating temperature

-20 °C to + 75 °C

Leakage

Bubble tight

Pressure and gauge connections

1/8" NPT Female

Dimensions

diam.: 50 mm.

length: nominal 140 mm (variable 125/140 mm)

Weight

Approx. 1.5 kg

Application

Testpressure regulator

Installation

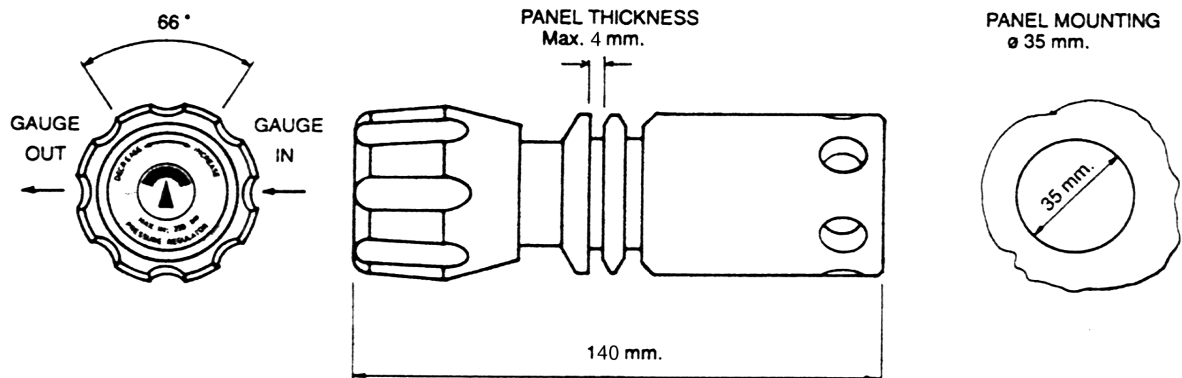

Distributor:

Rev.07.00/09.08E