



FEMA ELECTRÓNICA, S.A.

SERIE : MAG-35 Model : 32

FUNCTION : PROCESS WITH V_{EXC} .

Data Sheet:

154/95

REV. 1401/02

Instrument for reading process signals in D.C. with an excitation output for transducers and transmitters the available inputs are:
In voltage : 0-1 Vdc, 0-5 Vdc, 1-5 Vdc.
In current : 0-1 mA, 0-5 mA, 1-5 mA, 0-20 mA, 4-20 mA, 0-50 mA, 10-50 mAdc.

SPECIFICATIONS

| | |
|---------------------------|----------------------------------|
| DISPLAYS | 7 segments, red LED. |
| HEIGHT | 14.2 mm, (0.56"). |
| DECIMAL POINTS | Selectable by jumpers. |
| OVERRANGE INDICATION | Display flashes: 1999. |
| INPUT CONFIGURATION | Bipolar single. |
| ZERO | Automatic. |
| CONVERTER | Dual slope, average value. |
| POLARITY | Automatic \pm . |
| SIGNAL INTEGRATION PERIOD | 80 ms. |
| READ RATE | 3.12 / sec. |
| RANGES | See table fig. 7. |
| HOLD | Optional. |
| NOISE REJECTION N.M.R.R. | 50 dB. |
| ACCURACY | 0.15% \pm 1 count. |
| WARMUP TO RATED ACCURACY | 2 minutes. |
| SPAN TEMPCO | 100 p.p.m. |
| ZERO TEMPCO | 2.5 μ V / $^{\circ}$ C. |
| OPERATING TEMPERATURE | 0 to 50 $^{\circ}$ C. |
| STORAGE TEMPERATURE | - 40 to 80 $^{\circ}$ C. |
| WEIGHT | 310 gr. |
| CASE MATERIAL | ABS, black colour, DIN 43700. |
| STANDARD POWER | 230 Vac., \pm 10% 50/60 Hz. |
| POWER CONSUMPTION | 5.5 VA in AC. 3.5 W in DC. |
| ELECTRICAL CONNECTIONS | Screw-clamp connectors. |
| BURN-IN | 48 hours. |
| RECALIBRATION | 12 months. |
| EXCITATION OUTPUT: | Adjustable from 10 to 24 Vdc. |
| -OUTPUT CURRENT | 50 mA. maximum. |
| -RIPPLE AT 50/60 Hz | 0.2% @ 20 mA maximum. |

FIG. 1 FRONT VIEW

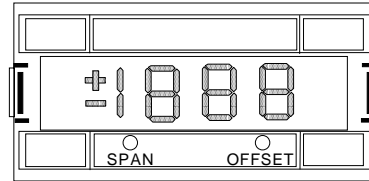

SPAN : Adjust the maximum reading.
OFFSET : Zero balance.

SPAN and OFFSET adjustment are accessible behind the low door.

FIG. 2 REAR VIEW

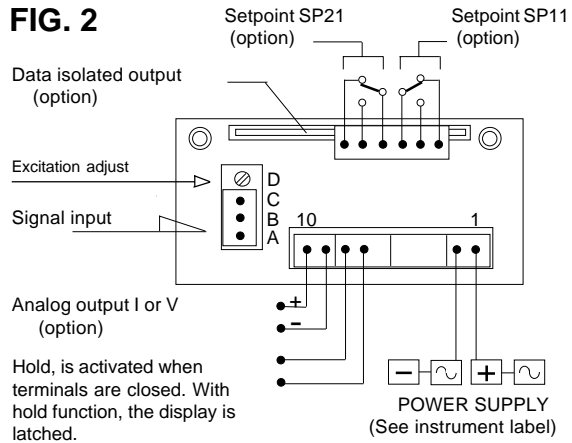
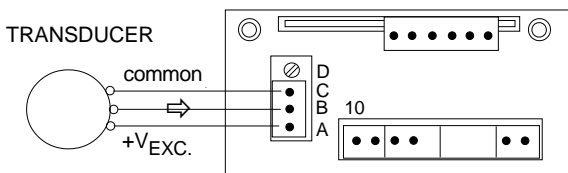

FIG. 3

ELECTRICAL CONNECTIONS FOR TRANSDUCERS OR TRANSMITTERS:

3 WIRE 4-20 mA TRANSDUCER POWERED BY THE INSTRUMENT



2 WIRE 4-20 mA TRANSMITTER OR TRANSDUCER POWERED BY CURRENT LOOP

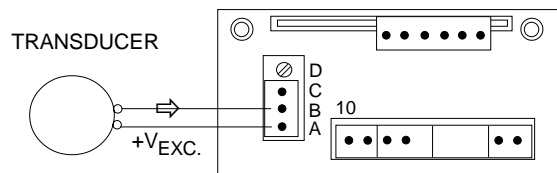

TRANSMITTER WITH CURRENT SIGNAL OUTPUT

Excitation supply V_{EXC} from external source.

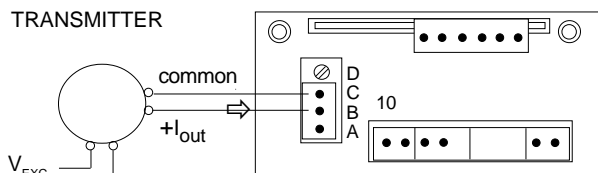

TRANSDUCER OR TRANSMITTER WITH VOLTAGE SIGNAL OUTPUT

Excitation supply V_{EXC} from external source.

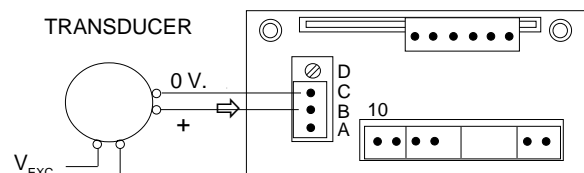

INPUT, SPAN AND OFFSET SELECTIONS

FIG. 7

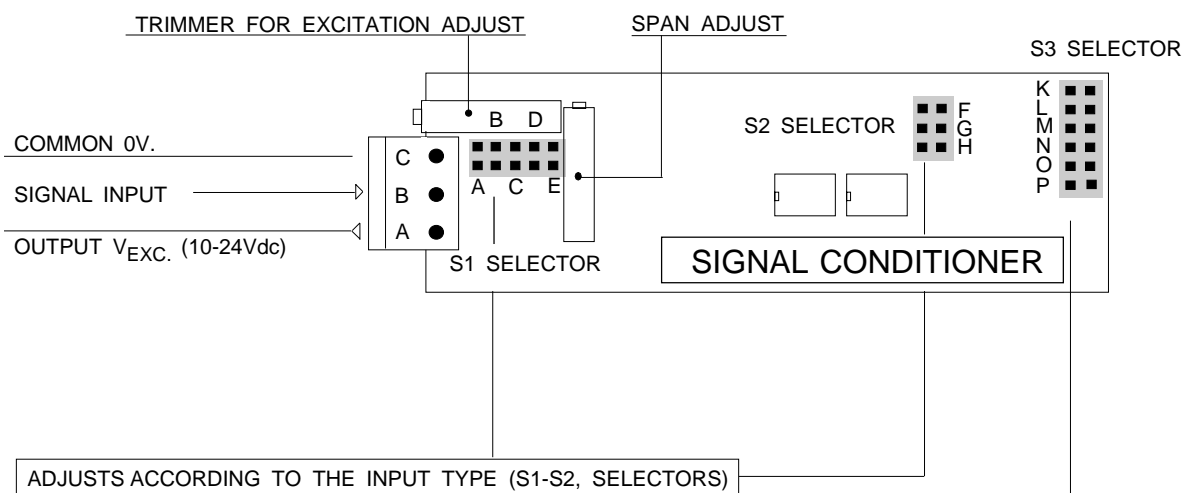

ADJUSTS ACCORDING TO THE INPUT TYPE (S1-S2, SELECTORS)

| SIGNAL INPUT | CLOSE JUMPERS | INPUT IMPEDANCE | MAXIMUM CURRENT |
|--------------|---------------|-----------------|-----------------|
| 0-1 V. | E,G | 1.1 M Ω | ----- |
| 0-5 V. | E,F,G | 1.1 M Ω | ----- |
| 1-5 V. | E,F | 1.1 M Ω | ----- |
| 0-1 mA | A,D,G | 100 Ω | 35 mA |
| 0-5 mA | A,D,F,G | 100 Ω | 35 mA |
| 1-5 mA | A,D,F | 100 Ω | 35 mA |
| 0-20 mA | A,C,F,G | 24.9 Ω | 70 mA |
| 4-20 mA | A,C,F | 24.9 Ω | 70 mA |
| 0-50 mA | A,B,F,G | 10 Ω | 100 mA |
| 10-50 mA | A,B,F | 10 Ω | 100 mA |

SPAN AND OFFSET ADJUSTS (S3 SELECTOR)

| SPAN RANGE | | OFFSET RANGE | | OFFSET | |
|----------------|--------------|----------------|--------------|--------|---|
| DISPLAY | CLOSE JUMPER | COUNTS | CLOSE JUMPER | + | - |
| 0 to 1.000 | K | 0 to 500 | P | O | M |
| 1.000 to 2.000 | none | 500 to 1.000 | none | | |
| 2.000 to 4.000 | L | 1.000 to 1.999 | N | | |

This signal conditioner can be configured for other signal inputs, which must be displayed in engineering units, and besides this to generate an offset for them, it be necessary.

OPTIONS AND POWER SUPPLY AVAILABLES FOR SERIAL MAG-35

OPTIONS : Select maximum one reference of each column

| OPTION | DESCRIPTION | OPTION | DESCRIPTION |
|--------|-------------------------------|--------|--------------------------|
| SDA | PARALLELBCD, OPTOISOLATED | SAK | ANALOG OUTPUT, mA SINK |
| SP11 | SINGLE SETPOINT, 3Amp. Relay | SAR | ANALOG OUTPUT, mA SOURCE |
| SP21 | DUAL SETPOINT, 3 Amp: Relays | SAB | ANALOG OUTPUT, VOLTAGE |
| MPA1 | ANALOG PEAK HOLD | MPA2 | ANALOG PEAK HOLD |
| SDS232 | ISOLATED SERIAL OUTPUT RS-232 | | |

STANDARD POWER SUPPLY

| OPTION | POWER | OPTION | POWER |
|--------|------------------|--------|------------------------------|
| 0 | 230 Vac 50/60 Hz | | |
| 1 | 115 Vac 50/60 Hz | 6 | 15...30 Vdc.(3.5 W) isolated |
| 2 | 24 Vac 50/60 Hz | 8 | 24...65 Vdc.(4 W) isolated |
| 3 | 48 Vac 50/60 Hz | | |

NOTE : The power supply ref. 4 is not available for those instruments with auxiliary power supply for transducers.

SELECTION OF : DECIMAL POINTS AND SPECIAL OPTIONS

FIG. 4

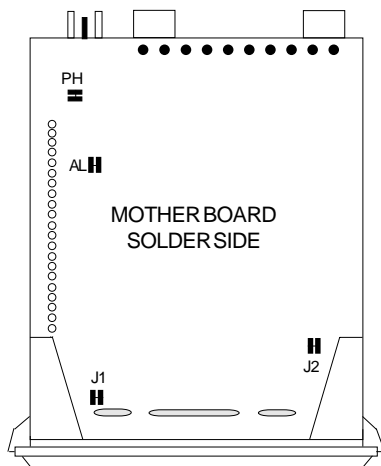

CONNECTOR FOR ANALOG OUTPUT (OPTIONAL)

POWER SUPPLY CONNECTOR

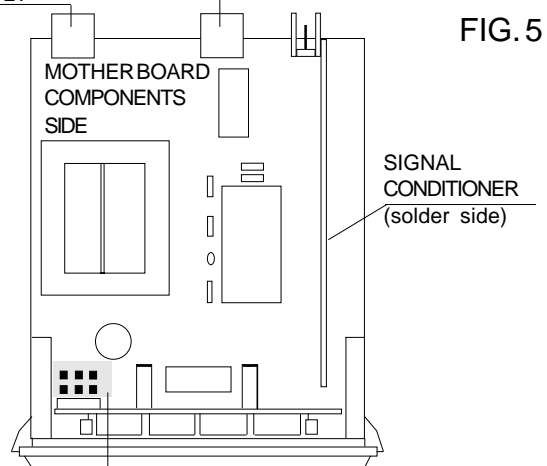
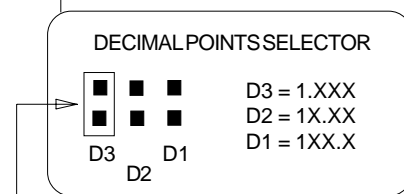

FIG. 5

JUMPERS SELECTION FOR SPECIAL OPTIONS

- AL: OPEN ONLY WHEN ADD SET POINTS CARD OPTION
- J1: OPEN TO ELIMINATE THE LEAST-SIGNIFICANT DIGIT (LSD)
- J2: OPEN TO ELIMINATE THE INDICATION +/-
- PH: OPEN WHEN ANALOG PEAK HOLD OPTION BE INSTALLED



INSTALL THE JUMPER IN THE ADECUATE PLACE, ACCORDING TO THE RANGE SELECTED.

FIG. 6

MECHANICAL DIMENSIONS mm (inch)

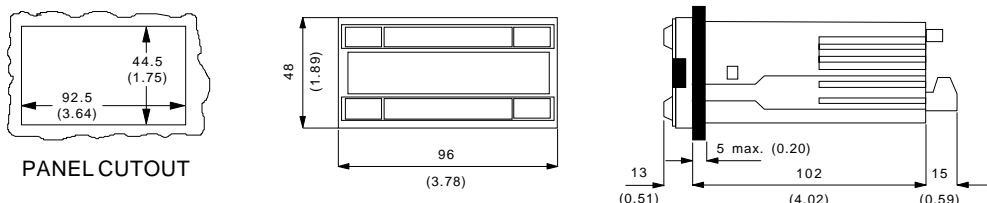

INSTALLATION

PRECAUTIONS



The installation and the future use of this unit must be done by suitably qualified personnel. This unit has not AC (mains) switch, neither internal protection fuse, it will be in operation as soon as power is connected. The installation must incorporate an external mains switch with a protection fuse, except for Serie BDF which has the fuse installed. The value of the fuse is indicated on the tables below. This unit can operate with Vac or Vdc, verify that the proper power option is installed for the power to be used.



SAFETY PRESCRIPTIONS

The unit has been designed and tested under UNE 20553 rules and is delivered in good condition. This data sheet contains useful information for electrical connections. Do not make wiring signal changes or connections when power is applied to the unit. Make signal connections before power is applied and, if reconnection is required, disconnect the AC (mains) power before such wiring is attempted. The unit cannot be installed in open places. Do not use until the installation is finished.



POWER SUPPLY

The power supply must be connected to the adequate terminals (see the connection instructions) The characteristics of the power supply are showed on the side label. Please make sure that the unit is correctly connected to a power supply of the correct voltage and frequency. Do not use any other power supply otherwise permanent damage may be caused to the unit. Do not connect the unit to power sources heavily loaded or to circuits which power loads in cycle on-off or inductive loads.

WARNING: If the power supply is DC voltage, be careful with the polarity indicated for each terminal. (see the connection instructions).



SAFETY CONSIDERATIONS PRESCRIPTIONS

Before starting any operation of adjustment, replacement, maintenance or repair, the unit must be disconnected from any kind of power supply. Keep the unit clean, to assure good functioning and performance, use for it a clean and humid rag. Do not use abrasive products, solvents, alcohol, etc... to clean the red filters and plastic parts of the unit. To prevent electrical or fire hazard, do not expose the unit to excessive moisture. Do not operate the unit in the presence of flammable gases or fumes, such an environment constitutes a definite safety hazard. The unit is designed to be mounted in a metal panel. If the unit shows signs of damage, or is not able to show the expected measures, or has been stored in a bad conditions or a protection failure can occur, then do not attempt to operate and keep the unit out of service.

IN CASE OF FIRE

- 1.- Disconnect the unit from the power supply.
- 2.- Give the alarm according to the local rules.
- 3.- Switch off all the air conditioning devices.
- 4.- Attack the fire with carbonic snow, do not use water in any case.

WARNING: In closed areas do not use systems with vaporized liquids.

RECOMMENDED FUSES FOR EACH SERIE OR MODEL

| | | | |
|-----------------|---------|---------|--------|
| Power Supply | 230 Vac | 115 Vac | 24 Vdc |
| Series : MAG-35 | 50mA | 100mA | |

DECLARATION OF CONFORMITY

Manufacturer: **FEMA ELECTRÓNICA, S.A.**
Address : Centro Industrial Santiga
c\Altimira, 14 (Talleres 14 - Nave 2)
E-08210 - Barberà del Vallès
SPAIN

DIRECTIVES:

EUROPEAN DIRECTIVE FOR LOW VOLTAGE D73/23/CEE AMENDED BY D93/68/CEE
Equipments powered from 50 to 1000 Vac. and / or from 75 to 1500 Vdc.

ELECTROTECHNICAL REGULATION FOR LOW VOLTAGE (RBT) ITC 21, ITC 29, ITC 35.
Equipments with power supply lower than 50 Vac. and/or 75 Vdc.

**EUROPEAN DIRECTIVE FOR ELECTROMAGNETIC COMPATIBILITY D89/336/CEE
AMENDED BY D93/68/CEE**

Conforming products :

Series : MAG-35

Models : 01, 02, 03, 04, 06, 07, 08, 10, 11, 12, 15, 16,
17, 20, 21, 22, 23, 24, 25, 26, 27, 32, 35, 36, 80, 90,
95

STANDARDS:

IMMUNITY
UNE EN 50082-1 (1997)

We hereby declare that the above products conform to the essential protection requirements of Directives and Harmonised Standards stated below.

EMISSIONS
UNE EN 50081-1 (1993)

ELECTRICAL SAFETY
UNE EN 61010-1 (1996)
UNE EN 60204-1 (1997)

Signed : Alex Pina
Position : Quality Manager
Place and Date : Barberà del Vallès, 2001

Recommendations

The panel meters of the current series have been designed in order to be mounted on metal panels, connected to earth.

NEVER lay together signal cables with power supply cables, through the same channel.

Whenever electromagnetic compatibility is an issue, use shielded cables, for both signal and power supply cables.

It is recommended to let the power supply cables go through a ferrite. If possible, let the cable cross twice through the ferrite, and maintain the ferrite the closest possible to the instrument.

It is recommended to let the signal cables go through a ferrite. If possible, let the cable cross twice through the ferrite, and maintain the ferrite the closest possible to the instrument.

Connect the shields of the signal cable and power supply cable to the metallic panel, which is at his side connected to earth.

Notes:

If electromagneteic interferences are atill an issue, try one or more of the following indications :

- use connectors with metallic shields when need to connect periferics to the system. Connect the shield of the cable to the shield of the connector.
- disconnect the cable shield of the power supply or/and signal cables.
- if your instrument is powered with direct current (DC), connect the negative terminal of the DC power, to the earth plug of the instruments power supply clamp.
- use a larger ferrite in the signal and/or the power supply cables.
- make the signal and/or power supply cables the shortest possible.