

Series BDF Counters

LARGE DISPLAYS for Counting Impulses

BDF-xx-T1 Counter

BDF-xx-T2 Counter

BDF-xx-T3 Counter

BDF-xx-T5 Counter

BDF-xx-T6 Counter



IDEAL SOLUTION for reading counting values at long distances from standard signals NPN, PNP, MECHANICAL, NAMUR, Very strong housing and electrically protected units, designed for all type of industrial applications.



FEMA ELECTRÓNICA, S.A.

USER'S MANUAL

(HT3197-r060706)

Models BDF Counters

LARGE DISPLAYS for Counting Impulses

The BDF series of large displays for impulse counting applications is made of models «T1», «T2», «T3», «T5» and «T6». All units are available in 4 and 6 digits format with 57mm or 100mm digit height.

All units have negative led sign, «RESET» function active by mechanical contact, and recognize impulse signals from standard sensors NPN, PNP, Mechanical Contact, Encoder, ... Counted impulses are scaled with internal programmable «Scaling Factors» before loaded on display. This allows the display of engineering units (units, meters, liters, ...). The decimal point position is programmable.

The mechanical of the BDF instruments is a very strong and sturdy aluminium housing anodized in black color, for panel mount, and for wall mount as an option. The front lens is antirreflexive and is firmly inserted on the aluminium profile with a rubber gasket around, providing IP65 protection on the front.

The signal wires are connected to plug-in screw clamps for higher security of the connections, accesible at the rear side of the instrument. The power is connected to a 3 terminal plug (2 power connections and 1 earth) containing an integrated protection fuse and an additional fuse as spare part.

0.- ORDERING REFERENCE

	Size	Model	Power	Color	Counting	Dec.Point	Sensor
BDF							
	24 26 44 46	T1 T2 T3 T5 T6	230 Vac 115 Vac 24 Vdc	R - Red	1 imp = 1.0 1 imp = 0.56 ...	XXXXX.X XXXX.XX ...	NPN Contact ...

1.- SIZES

SIZE BDF-24 .- Instrument with 4 digits
57mm digit height

SIZE BDF-26 .- Instrument with 6 digits
57mm digit height

SIZE BDF-44 .- Instrument with 4 digits
100mm digit height

SIZE BDF-46 .- Instrument with 6 digits
100mm digit height

2.- MODELS

MODEL BDF-xx-T1 .- Counter ADD with INHIBIT function when connecting «Input2» to a logical «0» signal.

MODEL BDF-xx-T2 .- Counter ADD with SUBSTRACT function when connecting «Input2» to a logical «0» signal.

MODEL BDF-xx-T3 .- Counter ADD and SUBSTRACT with independent inputs. ADD impulses on «Input1» and SUBSTRACT impulses on «Input2»

MODEL BDF-xx-T5 .- Counter for quadrature signals (typical from bidirectional encoder) with automatic ADD/ SUBSTRACT depending on phase differences between signals «A» and «B» (encoder turning clockwise or counterclockwise). 1 full cycle is 1 impulse.

MODEL BDF-xx-T6 .- Counter for quadrature signals (typical from bidirectional encoder) with automatic ADD/ SUBSTRACT depending on phase differences between signals «A» and «B» (encoder turning clockwise or counterclockwise). 1 full cycle is 4 impulses.

3.-FRONT AND REAR VIEW

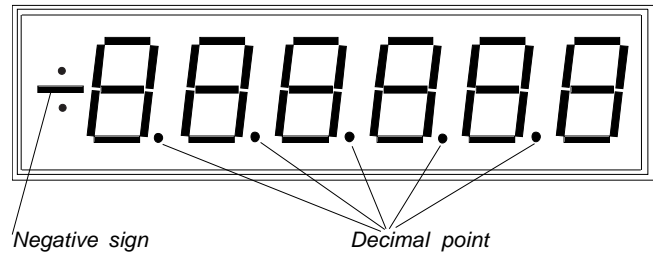
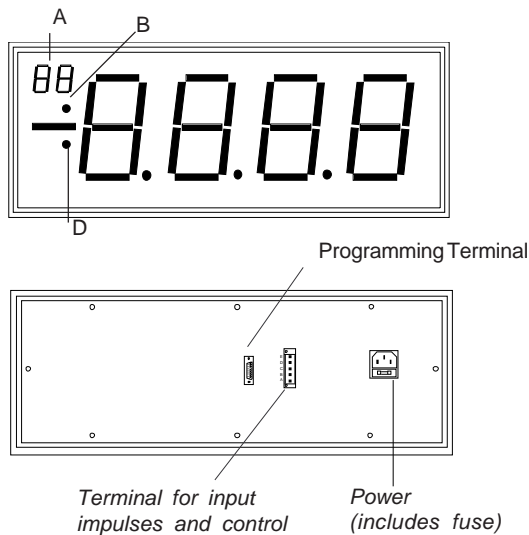

The BDF Counter units are available in 4 and 6 digits format. All digits are 7 segment LED type with decimal point, negative sign and red color

Leds «B» and «D» are lighted when the unit is being reprogrammed through the «Programming Terminal» on the rear cover. (See section 10 for more information).

Digits «A» are only available in units with 4 digits. These small digits will light only when the unit is being reprogrammed through the «Programming Terminal» on the rear cover. (See section 10 for more information).

4.-GENERAL CHARACTERISTICS

DISPLAY	4 or 6 digits red color Led type 7 segments	FREQUENCY	model «T1» maximum 10 KHz model «T2» maximum 10 KHz model «T3» maximum 4 KHz model «T5» maximum 5 KHz model «T6» maximum 2,5 KHz
DIGIT	57mm (2,3") BDF-24 and BDF-26 100mm (4,0") BDF-44 and BDF-46	Vexc	+15 Vdc (±20%, 100mA)
READING	from -9999 to 9999 in 4 digits from -999999 to 999999 in 6 digits	HOUSING	extruded aluminium anodized in black color for panel mount (optional for wall mount)
FRONTAL	antirreflexive filter IP65 protection on front filter	POWER	standard 230 Vac 50/60 Hz optional 115 Vac 50/60 Hz optional 24 Vdc isolated
DECIMAL PONT	selectable	CONSUMPTION	6 VA sizes BDF-24 and BDF-26 12VA sizes BDF-44 and BDF-46
NEGATIVE	negative sign «-»	WEIGHT	see section 18
SENSORS	NPN Vmax on terminals +28Vdc PNP Vmax on terminals +28Vdc NAMUR Vmax on terminals +28Vdc MECHANICAL CONTACT Pick-Up	ENVIRONMENTAL DATA	
PICK-UP	150 mVpp sensibility 100 mV hysteresis 26,5 KOhms Impedance 60Hz Vmax ±50Vdc	Working Temp.	from 0 to +50°C (32/122 °F)
		Storage Temp.	from -20 to +85°C (-4/185°F)
		Relative Hum.	from 0 to 85% non condensed

Note .- Sensor Type selectable by internal jumpers

5.- CONNECTIONS FOR POWER SUPPLY

The power connector allows one terminal for earth and two power terminals. Internal fuse is integrated on the connector and an additional fuse is available as a spare part. The value of the fuses depends on the power supply, and is according to rule IEC127/2

- 230 Vac - 200 mA fuse time-lag
- 115 Vac - 400mA fuse time-lag
- 24 Vdc - 350 mA fuse fast

Alimentación
230 Vac (115 Vac opcional)

Alimentación
24 Vdc Aislada

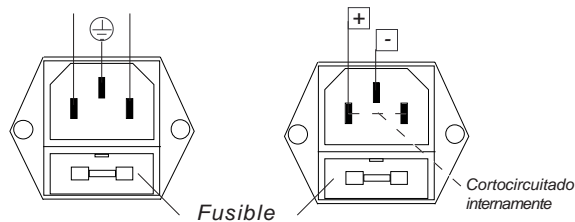

6.- INTERNAL JUMPERS (TRIGGER LEVELS, ANTIREBOUND FILTER)

The instrument can select two levels of trigger for different NPN, PNP and NAMUR sensors, different types of input signals and two levels of filters. To access the selection jumpers, unscrew the rear side cover and locate the «Control Board» with the selection jumpers.

* Trigger levels for NPN, PNP, NAMUR

Trigger Level «LOW» .- Jumper H,G Closed

Logical Level «1» >3.75 Vdc
Logical Level «0» <1.50 Vdc

Trigger Level «HIGH» .- Jumpers H,G Open

Logical Level «1» >7.50 Vdc
Logical Level «0» <5.50 Vdc

* Antirrebound filter .- Jumpers J,K

Closed .- Antirrebound filters at < 100 Hz
Open.- Antirrebound filters at < 10 KHz

Note .- Use filters at <100Hz for inputs type mechanical contact, in order to filter rebounds on the contact.

* Sensor Selection .- see section 9

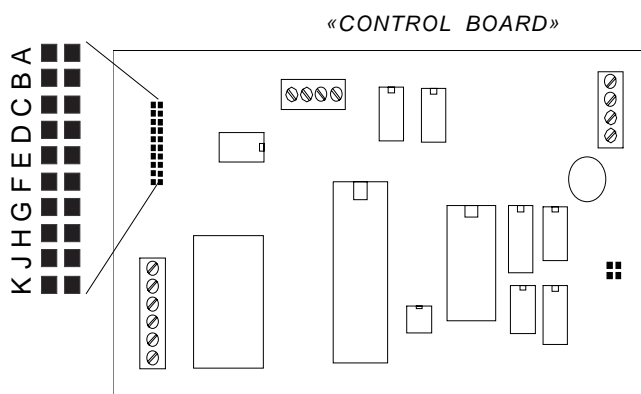

7.- RESET CONNECTIONS

All BDF Counter units have «RESET» function by mechanical contact on the rear side of the instrument. Connection is done between terminals «E» (Reset) and «A» (Common).

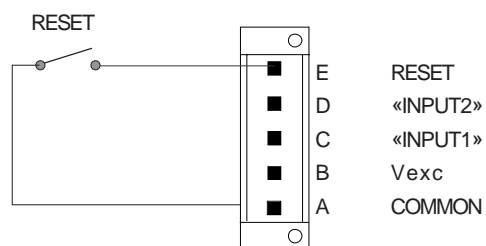

8.-INPUT SIGNAL TERMINAL

The input signal is connected to the 5 pole plug-in screw terminal at the rear side cover of the instrument.

Terminal «B» provides a +15 Vdc (maximum 100 mA) signal to power-up sensors and transducers. Do not use this terminal to power sensors and transducers that need higher current.

The 2 inputs of the instrument are connected to terminals «C» (Input1) and «D» (Input2). The function for «Input2» is dependent on the model.

Model BDF-xx-T1 .- «Input2» is INHIBIT function, when connected to a logical «0» state

Model BDF-xx-T2 .- «Input2» activates SUBSTRACT function when connected to a logical «0» state

Model BDF-xx-T3 .- Impulses at «Input2» SUBSTRACT

Model BDF-xx-T5 .- «Input1» and «Input2» are associated to signals «A» and «B» of quadrature signals (typical signal from bidirectional encoder)

Model BDF-xx-T6 .- «Input1» and «Input2» are associated to signals «A» and «B» of quadrature signals (typical signal from bidirectional encoder)

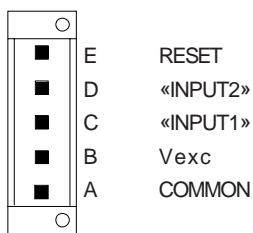

9.-INPUT SIGNAL SELECTION AND CONNECTIONS

MECHANICAL CONTACT

Select «INPUT1» terminal «C» (Signal) and terminal «A» (Common)
 «INPUT2» terminal «D» (Signal) and terminal «A» (Common)

Note -. close internal jumpers J,K. See section 6

NPN or PNP

NPN .- Jumpers ADF
 PNP .- Jumpers ABCDF

«INPUT1» terminal «C» (Signal), «A» (Common) and «B» (Vexc)
 «INPUT2» terminal «D» (Signal), «A» (Common) and «B» (Vexc)

NAMUR

Select «INPUT1» terminal B (Vexc), C (Signal)
 «INPUT2» terminal B (Vexc), D (Signal)

PICKUP

Select «INPUT1» terminal C (Signal) and A (Common)
 «INPUT2» not connected

10.-PROGRAMMING THE COUNTERS-INTRODUCTION

The BDF Counter instruments are configured by programming codes that activate internal «scale factors», decimal points, and other elements which scale the signal counted on display.

The programming of these codes is done through the 15 pin SUB-D connector at the rear side of the instrument. A «KBD Programming Keyboard» is needed, or the connections shown in Figure1 need to be set-up.

Buttons «1» to «6» introduce the numerical characters 1, 2, 3, 4, 5 and 6 on display, button «#» executes «ENTER» on the displayed code. Button «*» adds negative sign in some codes.

Note .- When KBD (or contacts indicated in Figure1) are connected to the BDF, the point placed under the negative sign will light. This led must be «on» during the reprogramming of the unit (if the led is not lightning, but the led on top of the negative sign lights, then press «*» to swtich leds).

Note .- When KBD (or contacts indicated in Figure1) are connected to the BDF Ratemeter with 4 digits, the 2 small 7 segment displays on top left part will light. These digits are needed to programm some codes which are 6 digit codes.

Figure1 .-

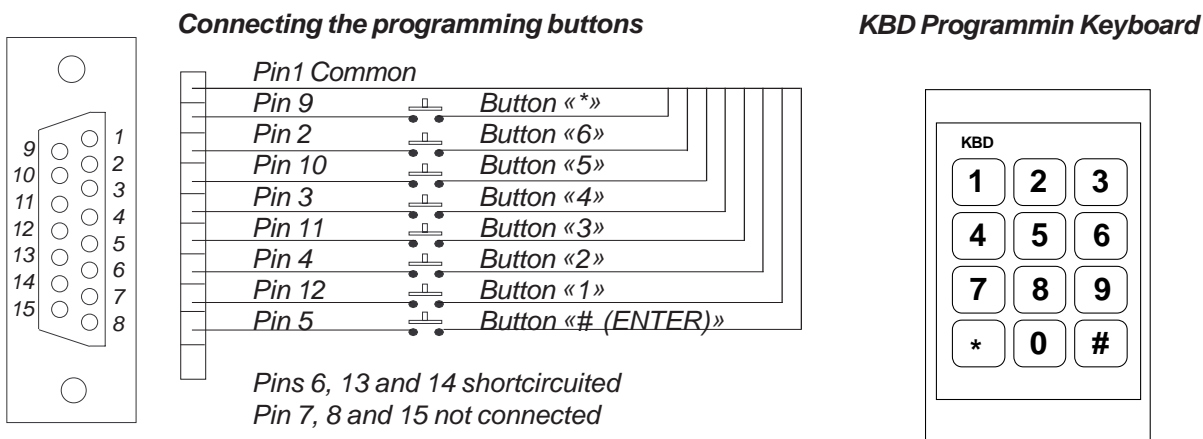

PROGRAMMING CODES

The programming codes are made of 2 digits identifying the code, and a third digit identifying the value assigned to the code.

Code «41» with value «1» is represented as «41 1#». Button «#» acts as a validation of the code and value entered. If this button is not pressed, the unit will not validate the new value.

EXAMPLE

Introducing code «41 1#»

- Press 4 Number 4 appears on display, to the left
- Press 1 Number 1 appears on display, to the left
The current value for code 41 appears to the right (it can be 1 or 2)
- Press 2 Number 2 appears on display, to the right replacing the previous value
- Press # Validates the code and the value entered (in this case 41 1)

Note .- After 6 seconds without introducing data, the instrument will cancel the programming code without validation.

Note .- Codes «1», «2» and «3» are special codes composed by only 1 digit. The value is a 6 digit numerical value and will load on display as soon as the code is pressed. The way to modify this value is to modify each digit value independently by pressing 1 to 6 and then # to validate the whole.

11.-PROGRAMMING THE COUNTERS - RESET AND MODEL SELECTION

«41 -1#» Resets the instrument configuration. Activates the default parameters
To place the negative sign, introduce codes «4», «1», «1», «*» and «#»

Note .- The led under the negative sign must be ON during the programming. If it is not lightning and the led on top of the negative sign is on, then press «*» to switch leds.

Codes «43» select the type of counter to be active

«43 1#»	BDF-xx-T1	«Input1» impulse input «Input2» control for inhibit	Maximum frequency 9 KHz Inhibits at logical «0» state
«43 2#»	BDF-xx-T2	«Input1» impulse input «Input2» control for Add/Substract	Maximum frequency 9 KHz Substracts at logical «0» state
«43 3#»	BDF-xx-T3	«Input1» impulse input Add «Input2» impulse input Substract	Maximum frequency 5 KHz
«43 4#»	<i>this code does not apply</i>		
«43 5#»	BDF-xx-T5	«Input1» bidirectional encoder channel «A» «Input2» bidirectional encoder channel «B»	Maximum frequency 4,5 KHz Quadrature signal x1
«43 6#»	BDF-xx-T6	«Input1» bidirectional encoder channel «A» «Input2» bidirectional encoder channel «B»	Maximum frequency 4,5 KHz Quadrature signal x4

12.-PROGRAMMING THE SCALE FACTORS

«3» «Scale Factor» is a multiplication and the value must be between «0.0000» and «5.9999». By default it is «1.0000»

«45 1#»	«Multiplication Factor» x1	Acts on the displayed impulses x0.1 ans show displayed counted impulses /10
«45 2#»	«Multiplication Factor» x0,1	
«45 3E»	«Multiplication Factor» x0,01	
«45 4E»	«Multiplication Factor» x0,001	

«44 1E»	«Multiplication Flanges» x1	(Counts on down flange)
«44 2E»	«Multiplication Flanges» x2	(Counts on down and rising flanges)

Note .- Not compatible with code «43 6E». Reduces maximum allowable frequencies to the half

13.-DECIMAL POINT POSITION

«46 1E»	0	Note .- Same codes but in negative allow visualization of zeros to the left. For example, code «46 -2#» will display «00000.0»
«46 2E»	0.0	
«46 3E»	0.00	
«46 4E»	0.000	
«46 5E»	0.0000	

14.-SPECIAL FUNCTIONS WITH «RESET» AND MEMORIES «AL1» AND «AL2»

«56 1E» When «RESET» is pressed, loads on display «000000»
 «56 2E» When «RESET» is pressed, loads on display «AL2» value and impulses substract from display
 «56 3E» *Does not apply*
 «56 4E» *Does not apply*
 «56 5E» When «RESET» is pressed, loads on display «000000»
 and when «AL2» value is reached, display loads «000000»
 «56 6E» When «RESET» is pressed, loads on display «AL2» value and impulses substract from display
 When reaching «000000» displays loads «AL2» value, and impulses substract from display

«1» Displays value of memory «AL1»
 «2» Displays value of memory «AL2»

To modify the memory values once loaded on display, press buttons 1,2,3,4,5,6 to modify each digit. Press «#» to apply the modified value.

15.- DEFAULT PROGRAMMING CODES

Default programming values	
«41 1#»	Default parameter
«42 3#»	Default parameter
«43 1#»	«Input1» input, «Input2» inhibit
«44 1#»	«Multiplication Flanges» x1
«45 1#»	«Multiplication Factor» x1
«46 1#»	no Decimal Point
«61 4#»	Default parameter
«62 1#»	Default parameter
«63 1#»	Default parameter
«64 4#»	Default parameter
«65 1#»	Default parameter
«51 2#»	«AL1» and «AL2» assigned to Counter
«52 3#»	Default parameter
«53»	Default parameter
«54 3#»	Default parameter
«55»	Default parameter
«56 1#»	Special functions. Normal reset
«66 1#»	Default parameter
«1»	500 Value of memory «AL1»
«2»	1000 Value of memory «AL2»
«3»	1.0000 «Scale Factor»

16.- LIMIT ON THE INTERNAL COUNTER

ATTENTION - Limit on the Internal Counter
 The BDF Counter instruments work with a 23 bit internal counter, allowing a maximum of 8.388.608 impulses to be counted (more than 8 million impulses). If this value is exceeded the sign led will activate and the counting will be subtracting from the display. Do a «RESET» and the counter will recover normal functionality. Also internal memory «AL2» can be programmed to release a «RESET» automatically when a predefined value on display is reached (code «56 5E»).

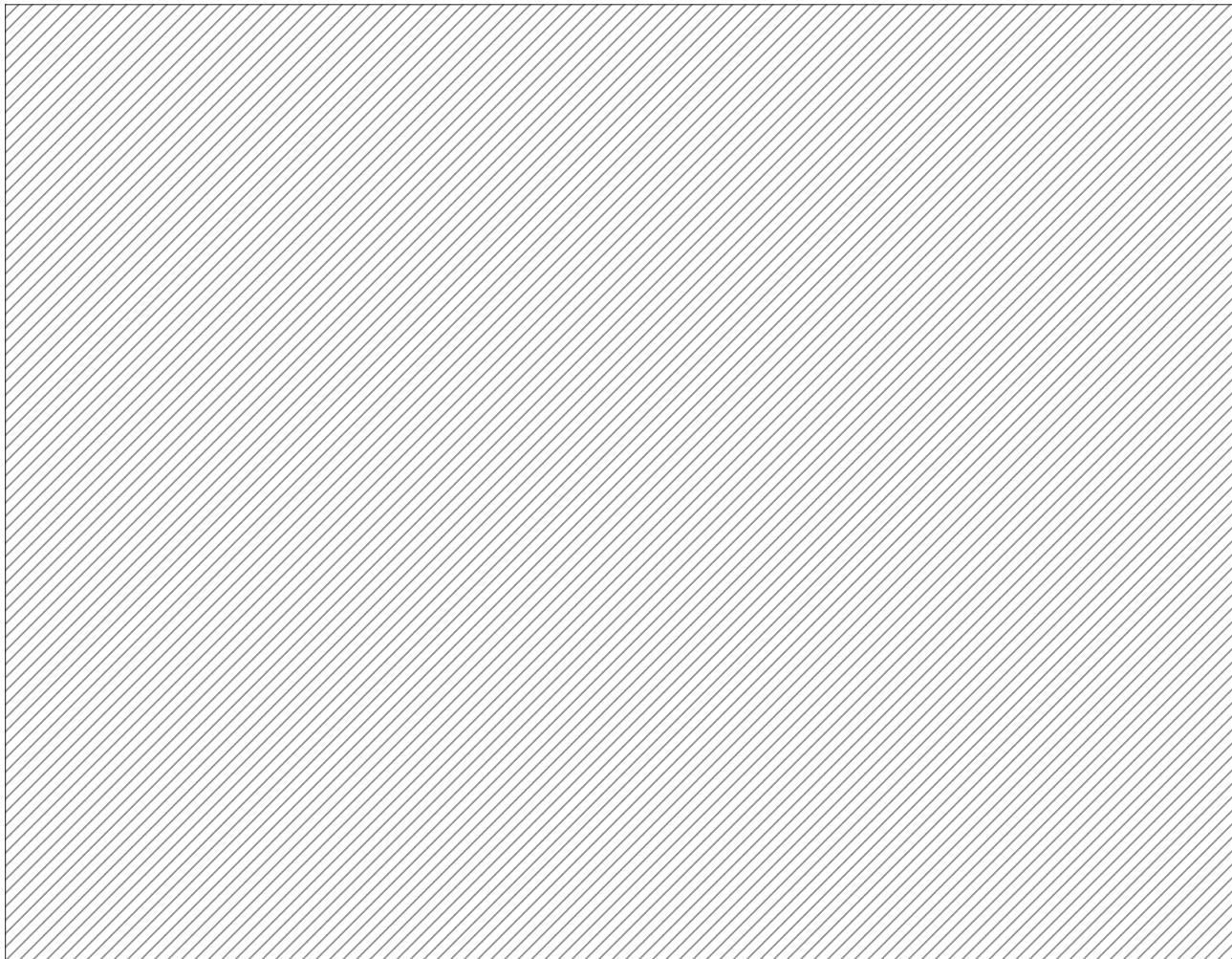

17.-PROGRAMMING EXAMPLES

The default programming for the BDF Counter units is 1 impulse = 1, this means each impulse adds +1 to the display. If changing this relation is needed, then the programming codes need to be accessed to change the scale factors of the unit. We take as an example the reprogramming to 1 impulse = 0,2785.

a.- The scale factors available and the values we can activate are the following :

«Scale Factor»	selectable between -5.9999 to +5.9999
«Multiplication Factor»	selectable between x1, x0.1, x0.001, x0.0001
«Multiplication Flanges»	selectable at x1 or x2

b.- To generate a total scale factor of 0,2785 we can assign the following values :

«Scale Factor»	= 2,785
«Multiplication Factor»	= x0,1
«Multiplication Flanges»	= x1

c.- The codes to programm are :

«3»	2,785
«45 2#»	
«44 1#»	

With this programming, each impulse received will add +0,2785 on memory. When 10 impulses have been received, display will show «0002».

d.- To programm the same relation 1impulse = 0,2785 but with 1 decimal, we programm the following way :

$$1 \text{ imp} = +0,2785 \quad \text{with reading XXX.X}$$

which is the same as 1 imp = 2,785 and light the decimal point :

e.- To generate a total scale factor of 2,785 we can assign the following values :

«Scale Factor»	= 2,785
«Multiplication Factor»	= x1
«Multiplication Flanges»	= x1
«Decimal Point»	=XXX.X

c.- The codes to programm are :

«3»	2,785
«45 2#»	
«44 1#»	
«46 2#»	Decimal point lightning at XXX.X

The possible combinations of scale factors and decimal points are very big. Take into consideration that the decimal point is only a led lightning, but it will not move the readings neither to the left nor to the right, and it will not multiply the reading in any case. Start always defining parameter «3» which is the only one able to define precise values, and then look for the appropriate fixed multiplication factors.

18.- SIZES AND DIMENSIONS

Size 24/26	A	B	C
4 digits 57mm (2")	264mm (10,40")	120mm (4,75")	112mm (4,41")
6 digits 57mm (2")	384mm (15,12")	120mm (4,75")	112mm (4,41")

Size 44/46	A	B	C
4 digits 100mm (4")	480mm (18,90")	180mm (7,09")	112mm (4,41")
6 digits 100mm (4")	668mm (27,10")	180mm (7,09")	112mm (4,41")

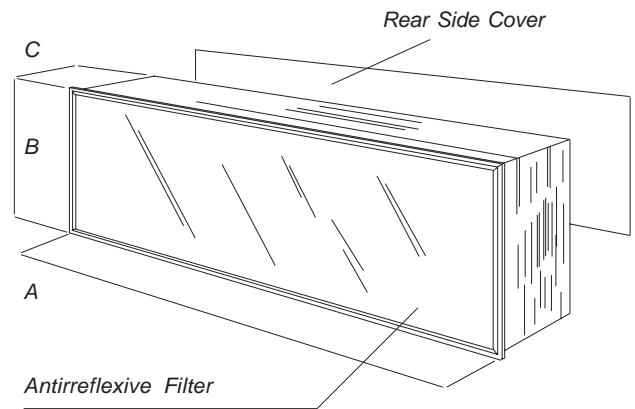

Note .- add 27mm to the «C» dimension for the power supply plug

19.- PANEL CUT-OUT AND WEIGHT

Size 24/26	D	E	Weight
4 digits 57mm (2")	256mm (10,07")	112mm (4,40")	2.3 Kg (5 lbs)
6 digits 57mm (4")	376mm (14,80")	112mm (4,40")	2.7 Kg (6 lbs)

Size 44/46	D	E	Weight
4 digits 100mm (4")	472mm (18,58")	172mm (6,77")	5.0 Kg (11,0 lbs)
6 digits 100mm (4")	680mm (36,77")	172mm (6,77")	5.7 Kg (12,5 lbs)

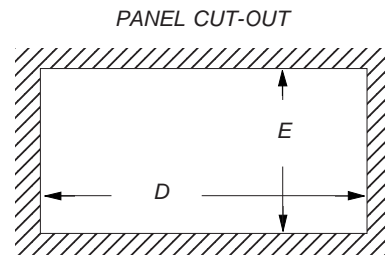

Panel width
Max. 14 mm (0,55")
Min. 2,5mm (0,10")

20.- PANEL INSTALLATION

Introduce the instrument «1» into the panel cut-out and place a fixation piece «3» on each side. Place the screw «2» through the fixation piece «3» until it presses the panel «4» and is firmly fixed.

Note .- The front of the instrument is sealed with a protection level IP65. To have the same level of protection between the panel and the instrument, place a rubber profile (squared or round) as indicated «5».

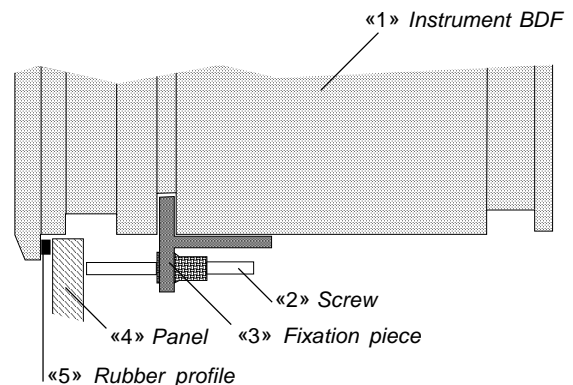

21.- SECURITY PRESCRIPTIONS



INSTALLATION PRECAUTIONS.- The installation and operation of this instrument must be done by qualified operators. This instrument DOES NOT have power switch and will start to operate as soon as the power supply is connected. The instrument has an internal protection fuse, according to IEC-127/2, and is located inside the power-supply connector. The values are

- Fuse 200 mA Time Lag (for 230 Vac power)
- Fuse 400 mA Time Lag (for 115 Vac power)
- Fuse 350 mA Fast (for 24 Vdc power)

When the instrument is used to control machines or processes where the personnel or the process can be damaged, the appropriate security elements must be added to the system in order to protect the operator and / or the system.



SAFETY PRESCRIPTIONS.- This instrument has been designed and verified according to the UNE-20553 rules and is delivered in perfect conditions of operation. This manual contains the adequate information for the electrical installation. Before starting operations for connections, readjustment, substitution, maintenance, repair, etc, the instrument must be unplugged from the power supply. The instrument must be installed in places with good ventilation to avoid excessive heating, and far from sources of electrical noise or magnetic field generators, such as power relays, electrical motors, speed controls, etc... The instrument can not be installed in open places. Do not use until the installation is finished. The instrument is designed to be mounted on a metallic panel with the adequate protections. DO NOT clean the front lens with abrasive products (such as solvents, alcohol, etc) use a clean and water humid rag. Do not expose the instrument to excessive moisture. DO NOT operate the unit in the presence of flammable gases or fumes.

EXCITATION VOLTAGE Vexc.-

Instruments BDF-xx-32 and BDF-xx-36 supply an excitation voltage of 10 to 24 Vdc (50mA) to power transducers, available between terminals A and C. Do NOT connect these terminals to an external power supply, permanent damages may result on both instruments.

22.- WARRANTY

FEMA ELECTRÓNICA, S.A. warrants this instrument free of defects for a period of 24 MONTHS from the date of shipment. This warranty covers both the materials of the instrument and the processes used for manufacturing.

POWER SUPPLY .- Connect the Power Supply to the terminals indicated in this manual. Verify that the voltage and frequency of the power supply is according to the voltage and frequency values indicated in the label attached to the unit. DO NOT connect the instrument to power lines which are overloaded, or power lines with loads working in ON/OFF cycles, or with inductive loads.



SIGNAL WIRING .- Information to consider relating the wiring of the sensors, probes, transducers, etc. The wires can act as antennas and introduce electrical noise from the environment into the signal wires, specially if the wires are close to noise sources or electromagnetic sources. There are several rules generally known which should be taken into consideration for the wiring :

- a.- DO NOT install impulse, control or signal wires together in the same conduits as the wires connected to power lines, connected to CC or AC engines, electromagnets, ...
- b.- When using shielded wires, connect the shield to the common of the instrument, and leave not-connected the probe side
- c.- The wires of impulse, control and signal should be placed in places far away from switches, transformers, control relays, etc...

IN CASE OF FIRE



- 1.- Disconnect the unit from the power supply.
- 2.- Give the alarm according to the local rules.
- 3.- Switch off all the air conditioning devices.
- 4.- Attack the fire with carbonic snow, do not use water in any case.

WARNING : In closed areas do not use systems with vaporized liquids.

23.- DECLARATION OF CONFORMITY

CE DECLARATION OF CONFORMITY

Manufacturer.- FEMA ELECTRÓNICA, S.A. Address.- Pol. Ind. Santiga - Altimira 14 (T14 - N2) E-08210 Barberà - BARCELONA ESPAÑA - SPAIN	DIRECTIVES EUROPEAN DIRECTIVE FOR LOW VOLTAGE D73/23/CEE AMMENDED BY D93/68/CEE. Equipments powered from 50 to 1000 Vac and/or from 75 to 1500 Vdc. EUROPEAN DIRECTIVE FOR ELECTROMAGNETIC COMPATIBILITY D89/336/ CEE AMMENDED BY D93/68/CEE
Conforming Products Series.- BDF-24, BDF-26, BDF-44 and BDF-46 Models.- T1, T2, T3, T5, T6	STANDARDS IMMUNITY UNE EN 50082-1 (1998) EMMISIONS UNE EN 50081-2 (1994) ELECTRICAL SAFETY UNE EN 61010-1 (1997) UNE EN 60204-1 (1998)
We hereby declare that the above products conform to the essential protection requirements of Directives and Harmonized standards indicated below.	NOTE .- During an electromagnetic disturbance (10V/m) it is permitted a worst case error of 1% of the A/D range. The instrument will recover automatically its functionality when the disturbance stops, without need of the operator to reset or restart.
Signed.- D. Juncà Position.- Quality Manager Place .- Barberà, 2005	

more products



Programmable
Panel Meters



Signal Converters &
Isolated Transmitters



Large Displays



Standard
Panel Meters



Miniature
Panel Meters



Large Displays
for TIME

www.fema.es

ELECTRONIC INSTRUMENTATION FOR INDUSTRY

FEMA ELECTRÓNICA, S.A.
Pol. Ind. Santiga - Altimira 14 (T14 - N2)
E-08210 Barberà - BARCELONA
ESPAÑA - SPAIN

Tel. (+34) 93.729.6004 - www.fema.es
Fax (+34) 93.729.6003 - info@fema.es